

Falttore
Alu AL601F 2.0
Alu AL602F
Alu therm. getrennt AL603F
Stahl ST602F
BR600

TECHNIK
Version 2023/11

SCHNEIDER Torsysteme Ges.m.b.H.
Kalzitstrasse 1
A-4611 Buchkirchen
Tel. +43 7243/545 88-0
Web. www.schneider.co.at



Gültig ab 01.11.2023

Alle bisherigen Unterlagen verlieren ihre Gültigkeit. Technische Änderungen, Druck- und Satzfehler, drucktechnische Farbabweichungen vorbehalten. Darstellungen sind nur beispielhaft.

Systemzeichnung Falttor AL601F 2.0, AL602F, AL603F, ST602F

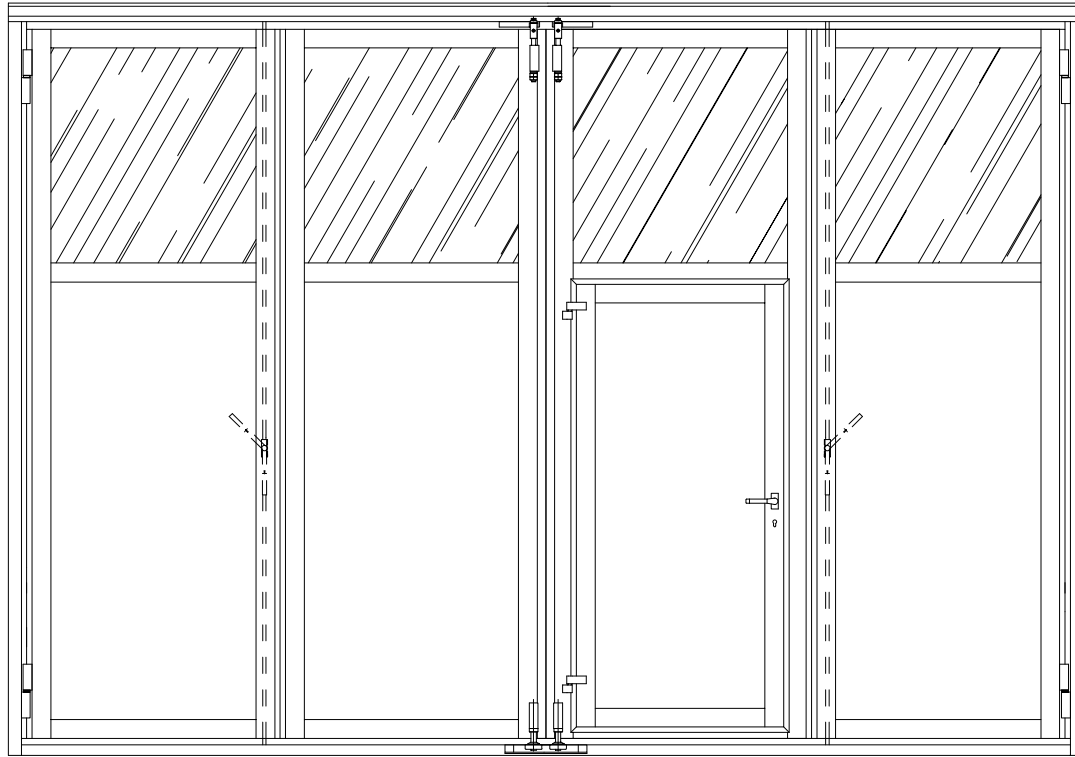

Horizontalschnitt

Vertikalschnitt

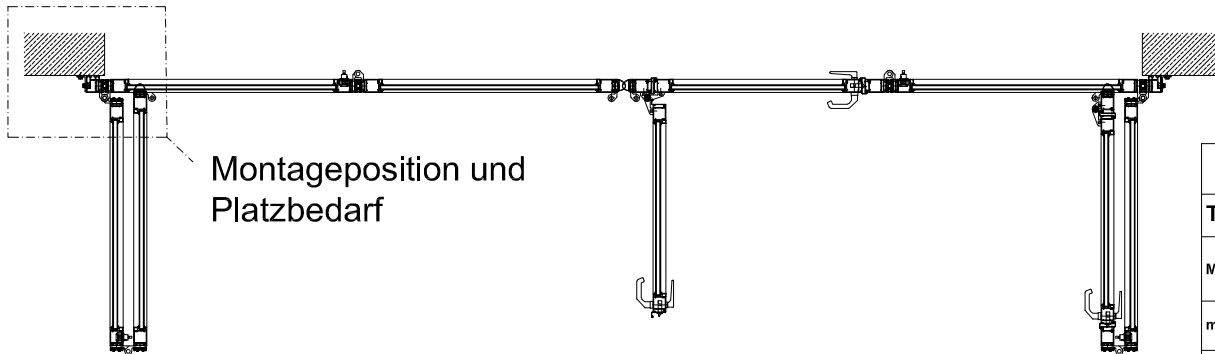
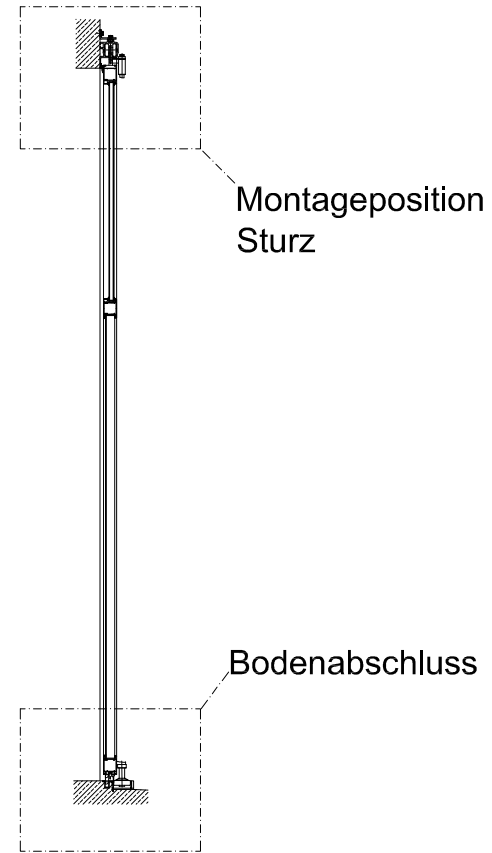

Montageposition und Platzbedarf

Größenbereich Falttor				
Type	AL601F 2.0	AL602F	AL603F	ST602F ST602SF
Material	Aluminium	Aluminium	Aluminium thermisch getrennt	Stahl
max. Torgröße BB x BH	10400x4800 mm	15600x5600 mm	15600x5600 mm	15600x7000 mm
max. Flügelbreite	1300 mm	1300 mm	1300 mm	1300 mm

Flügel-Platzbedarf

AL601F 2.0

90° Öffnung

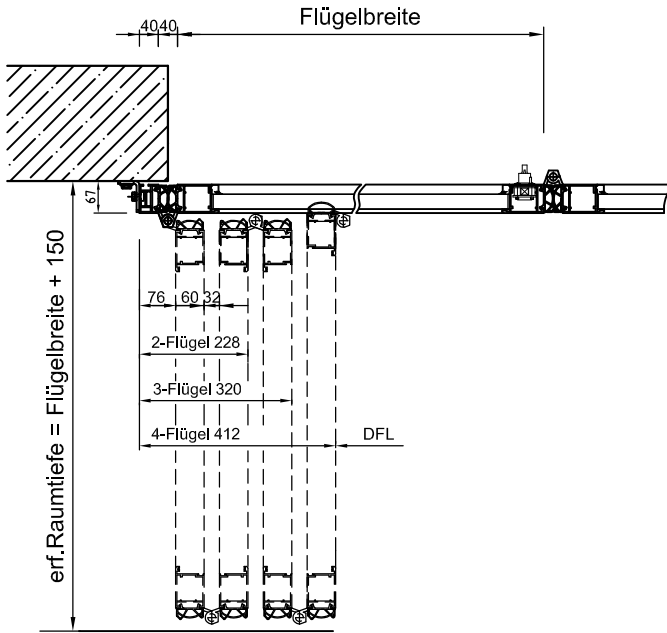

AL602F AL603F ST602F

90° Öffnung

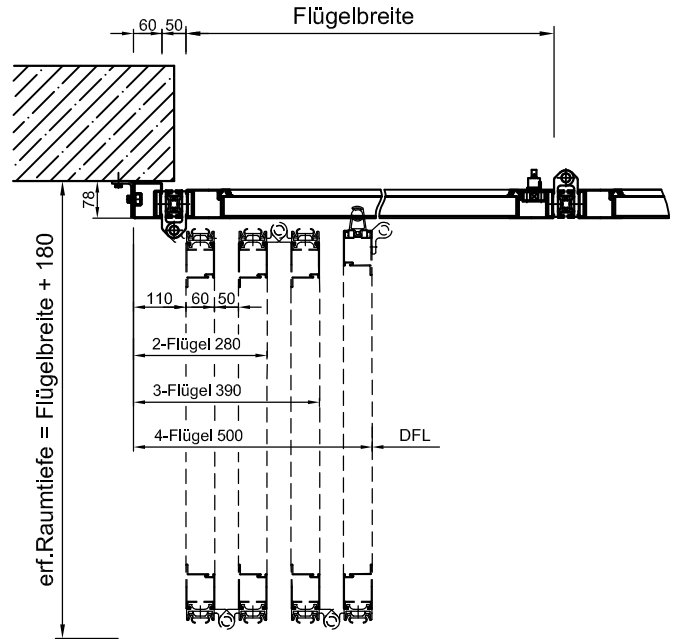

AL601F 2.0

180° Umlenkung (max. 3 Flügel, handbetätigt)

(keine durchgehende Bodenführung möglich)

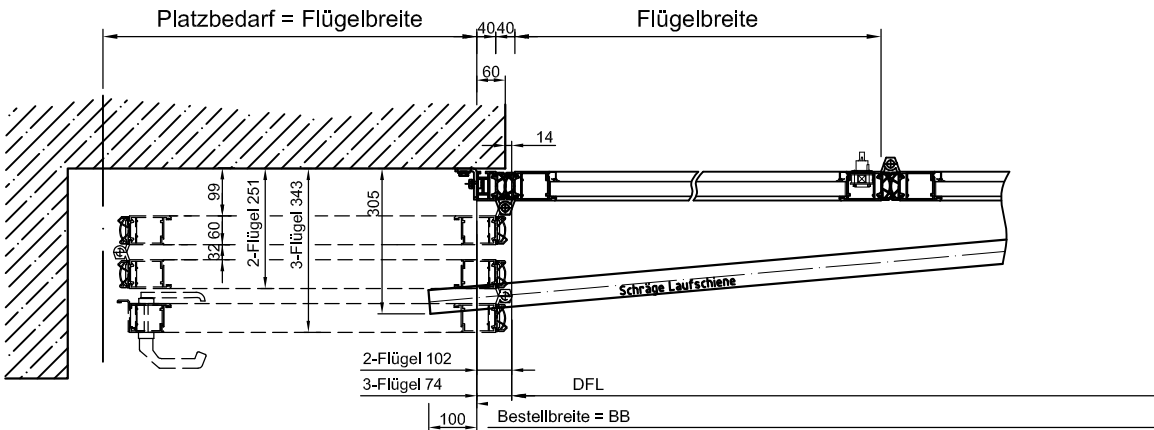

AL602F AL603F ST602F

180° Umlenkung (max. 3 Flügel, handbetätigt)

(keine durchgehende Bodenführung möglich)

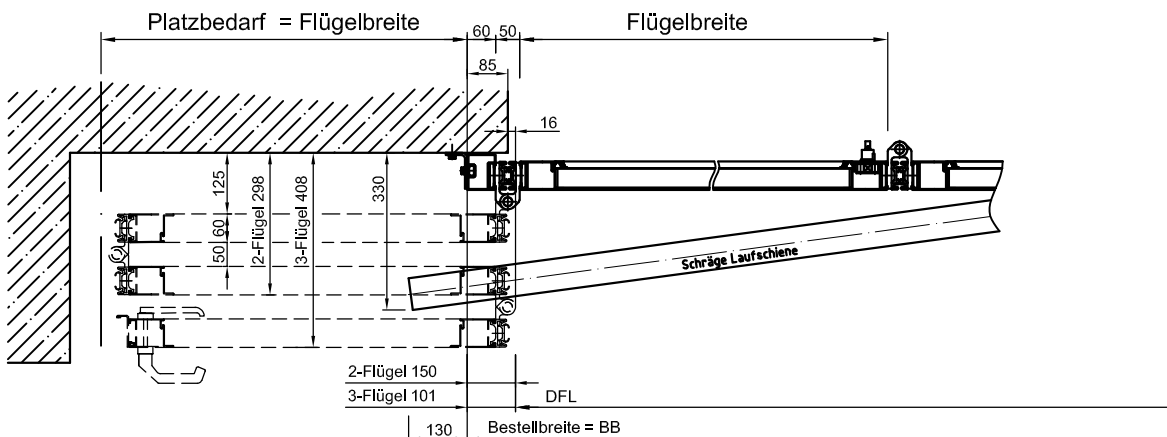

Montageposition Sturz vor/hinter der Leibung

AL601F 2.0

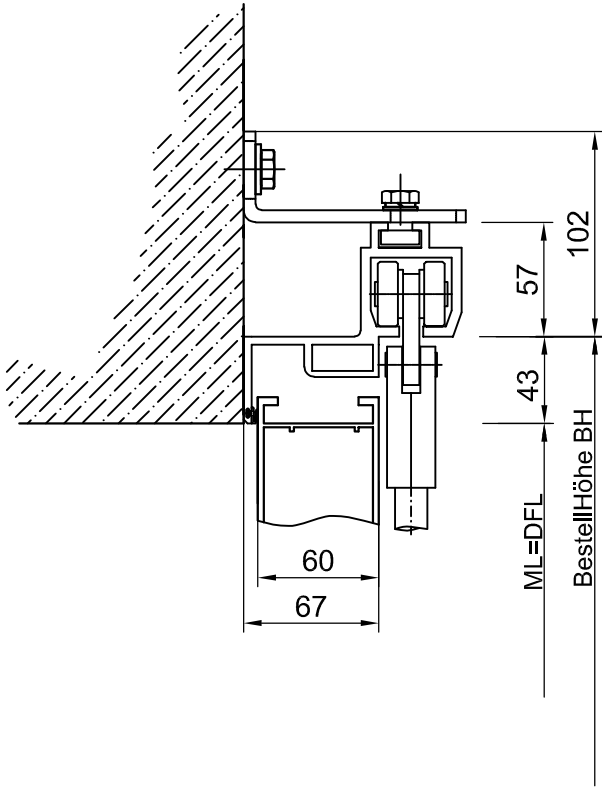

AL602F

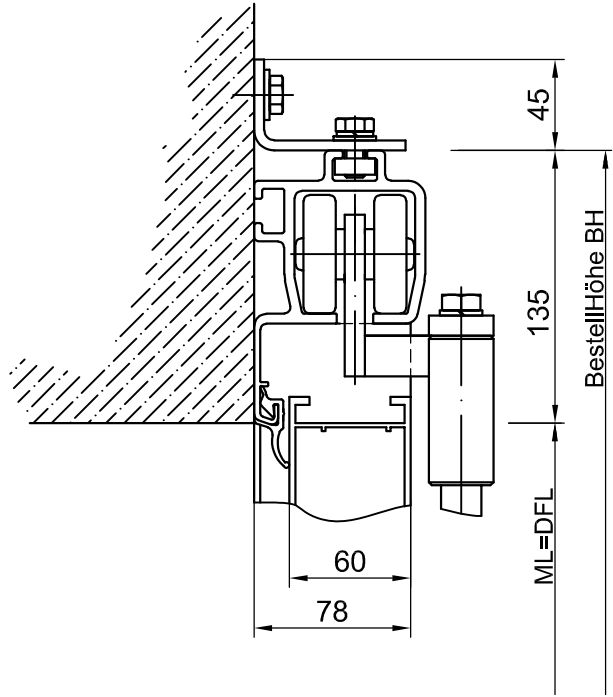

AL603F

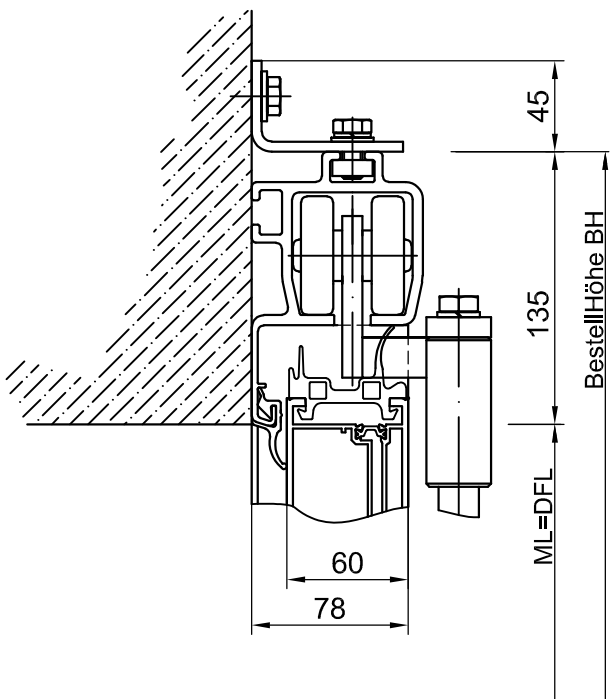

ST602F

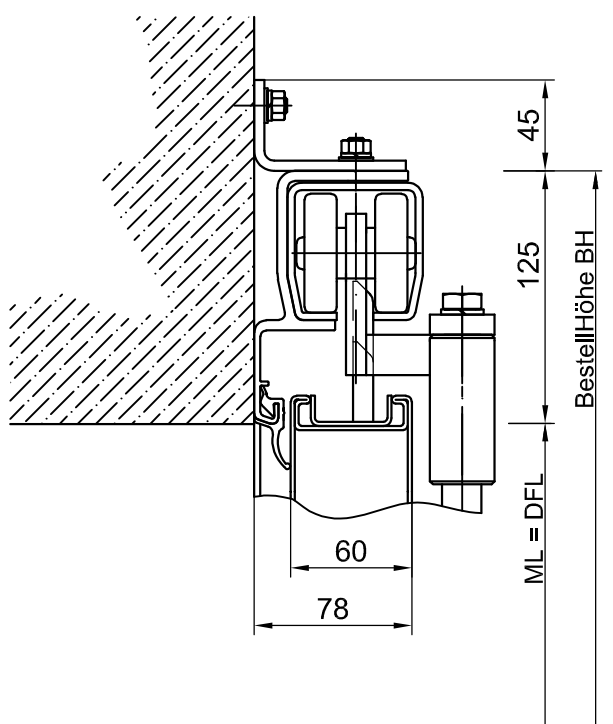

Montageposition Sturz in der Leibung

AL601F 2.0

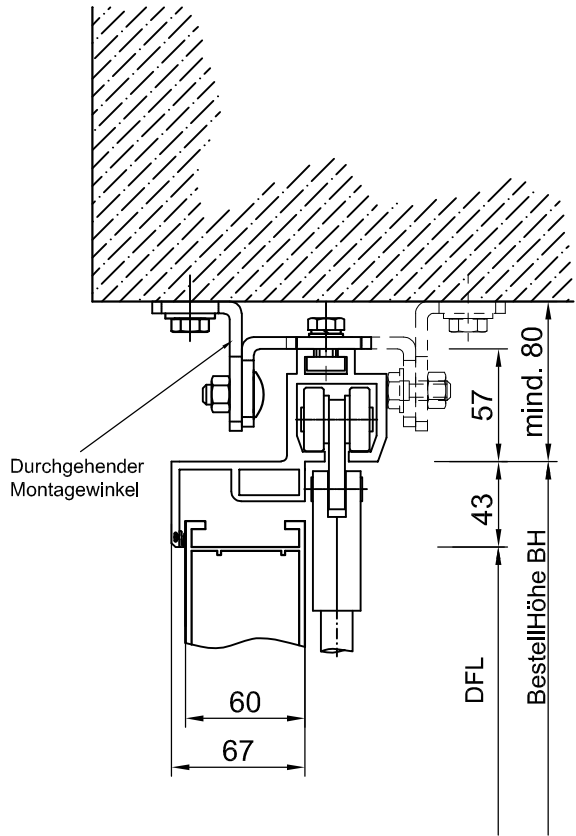

AL602F

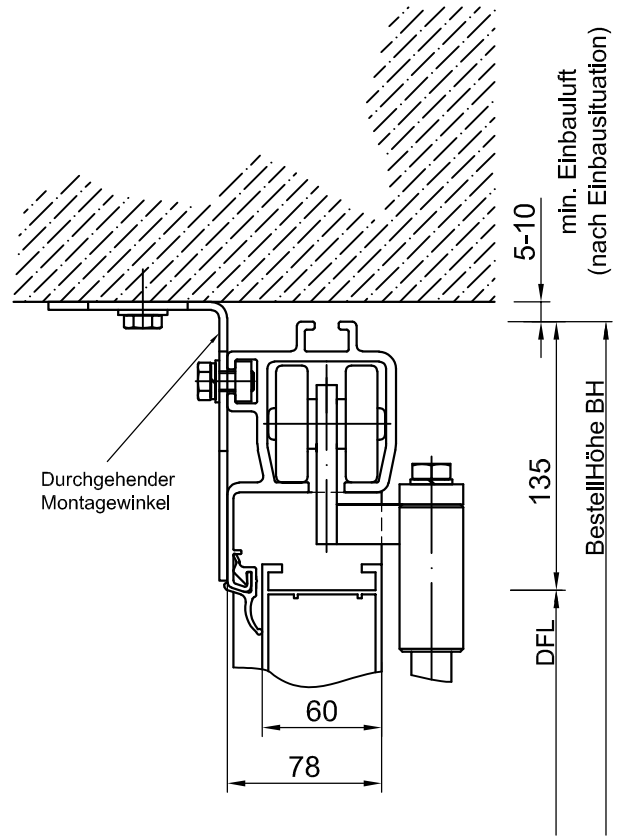

AL603F

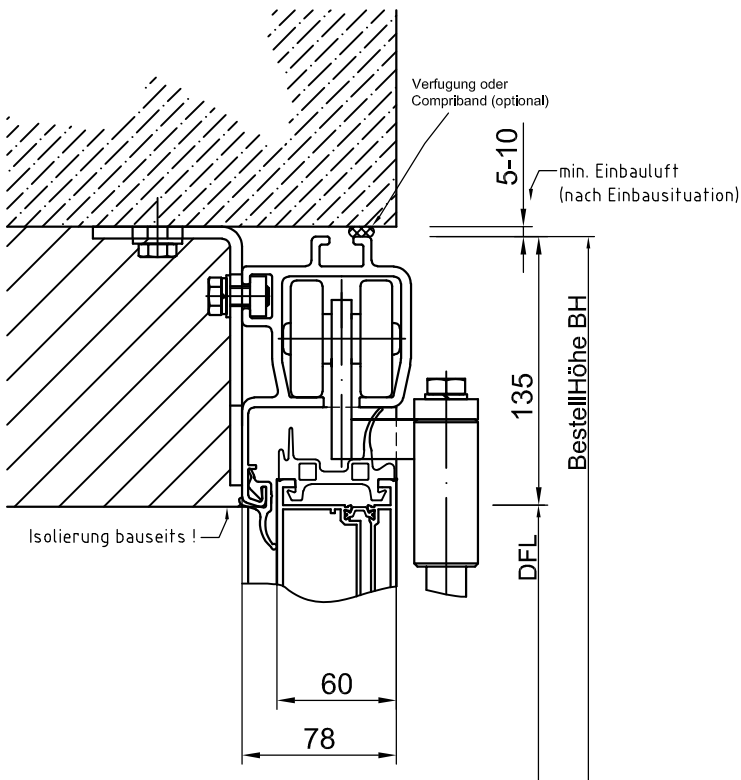

ST602F

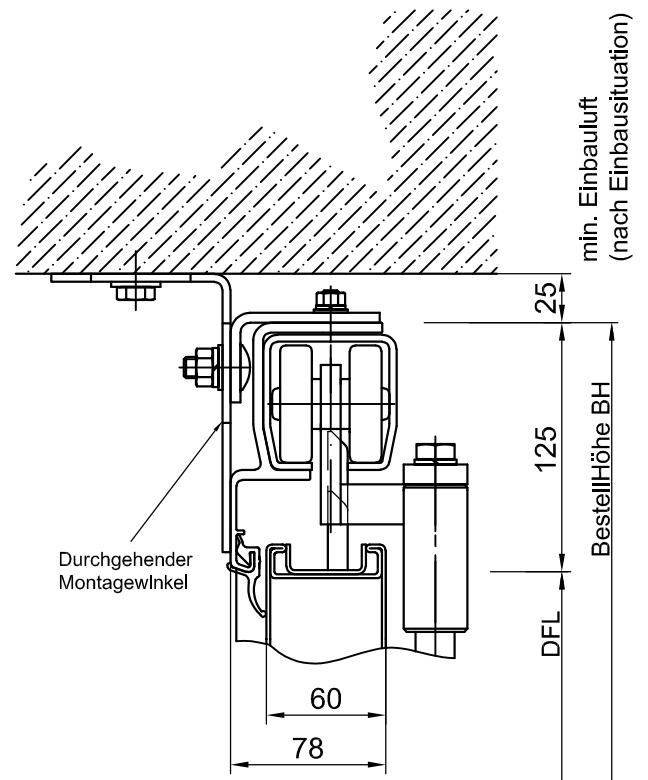

Montageposition Sturz Eckleibung

AL601F 2.0

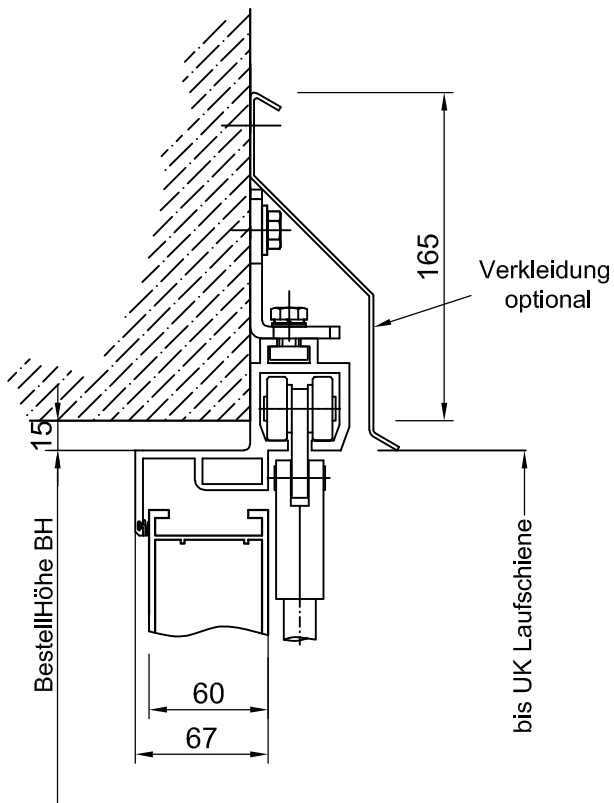

AL602F

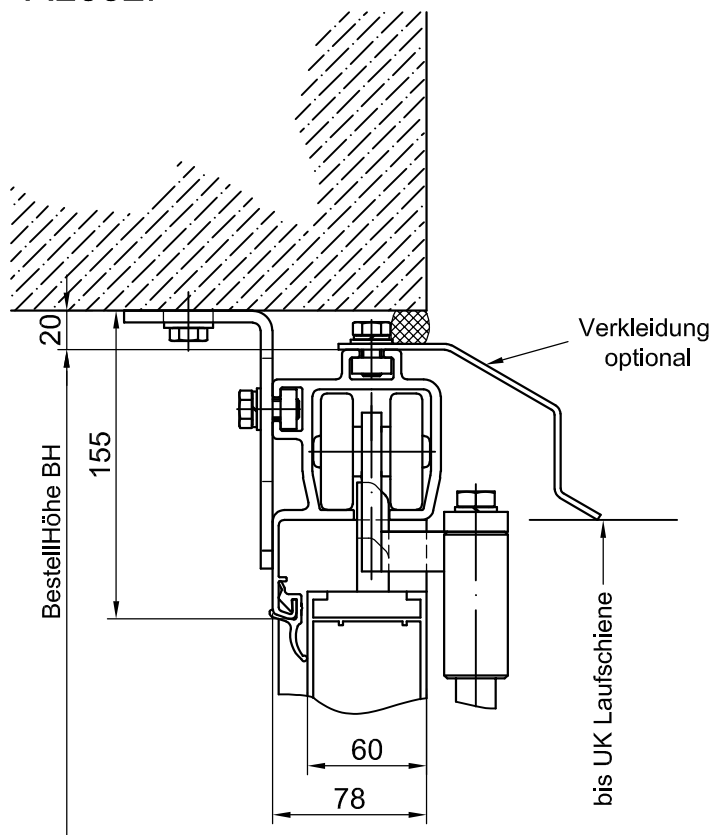

AL603F

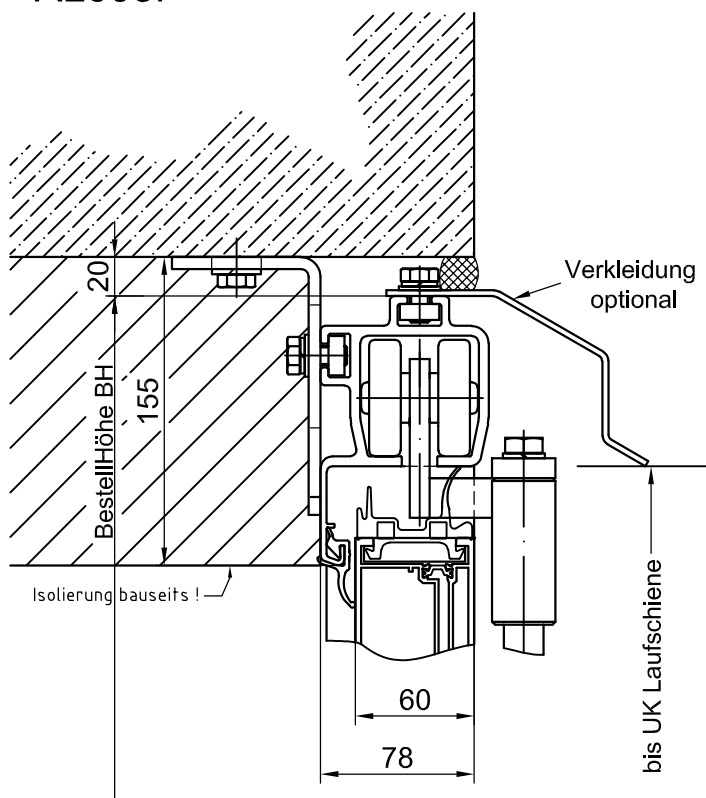

ST602F

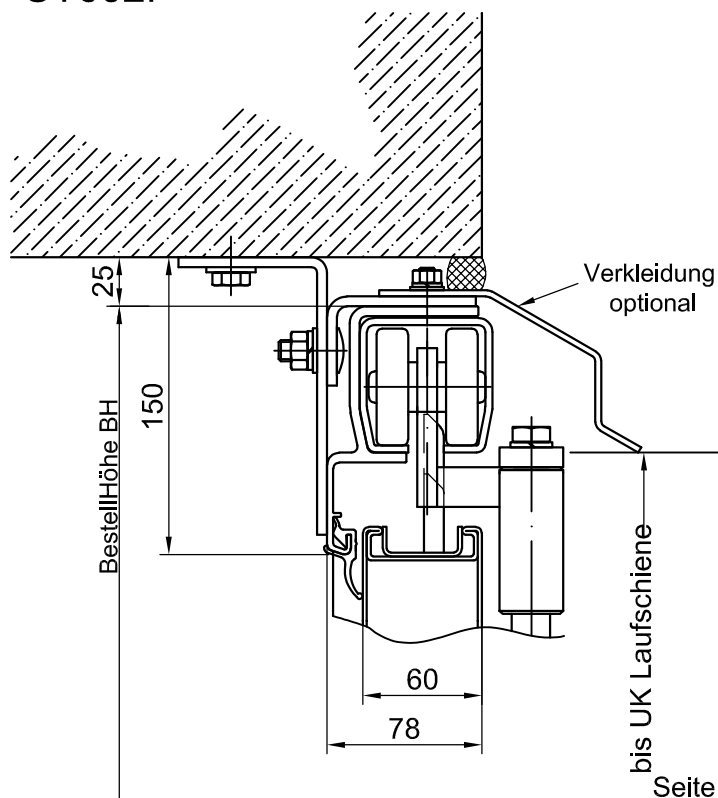

Montageposition vor/hinter der Leibung seitlich

AL601F 2.0

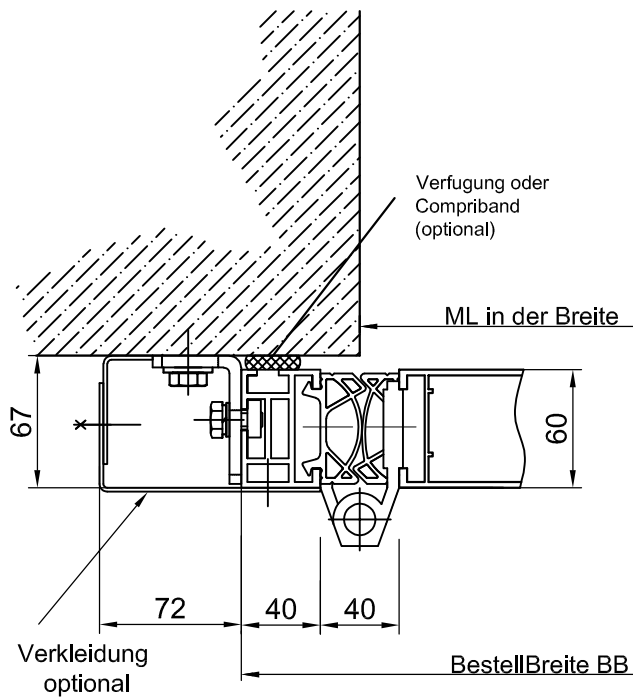

AL602F

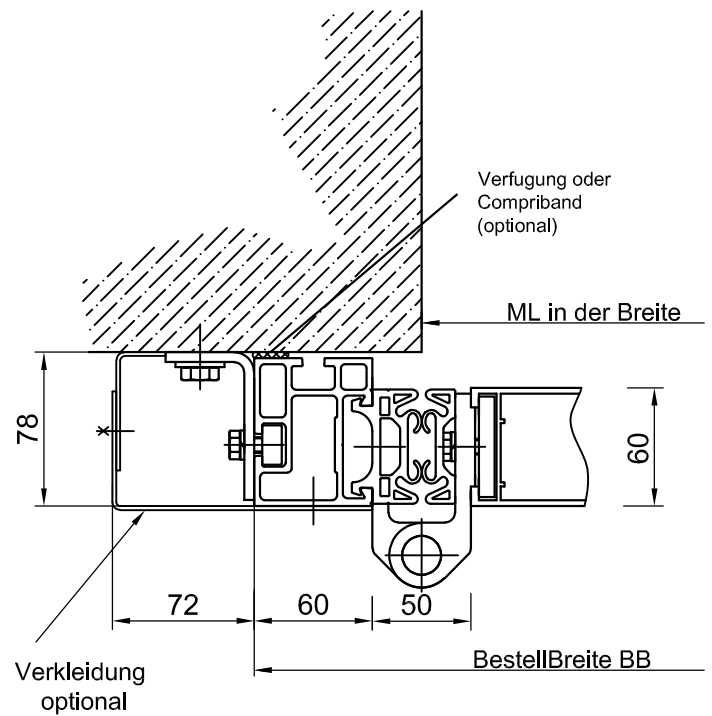

AL603F

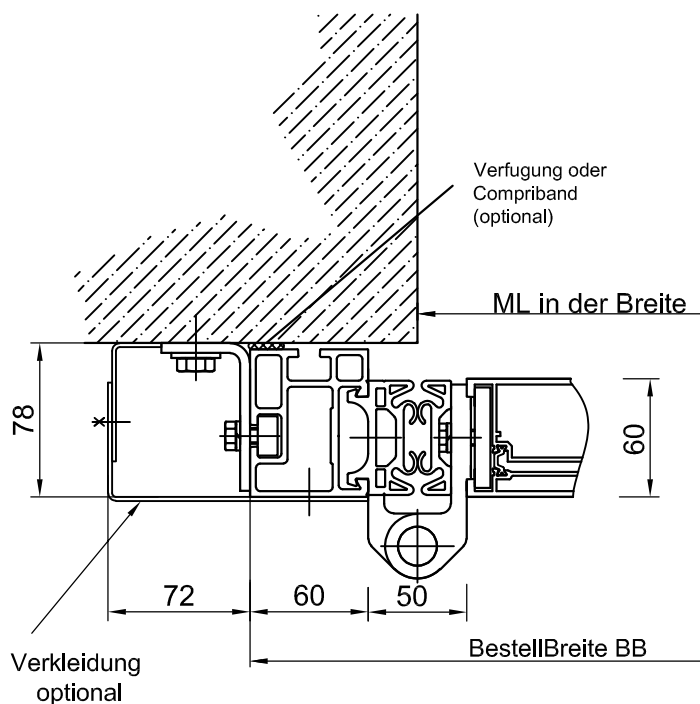

ST602F

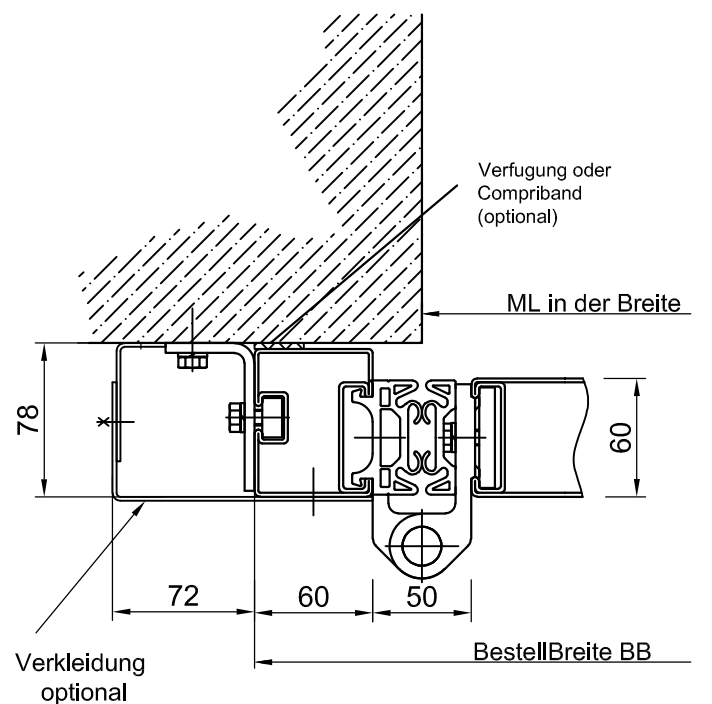

Montageposition in der Leibung seitlich

AL601F 2.0

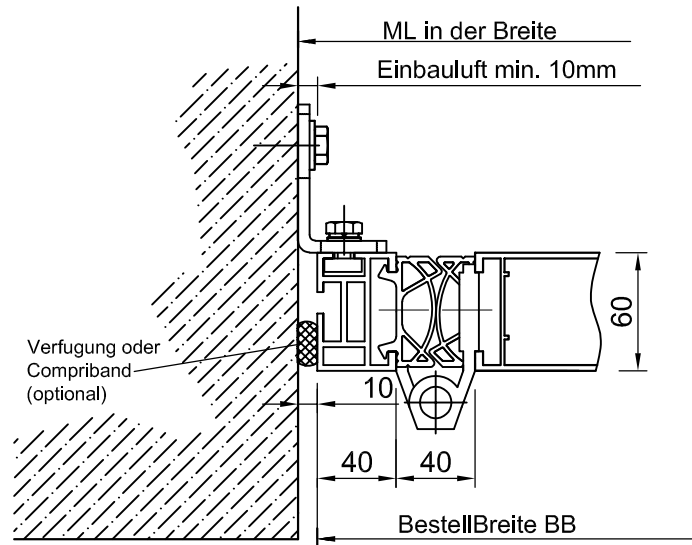

AL602F

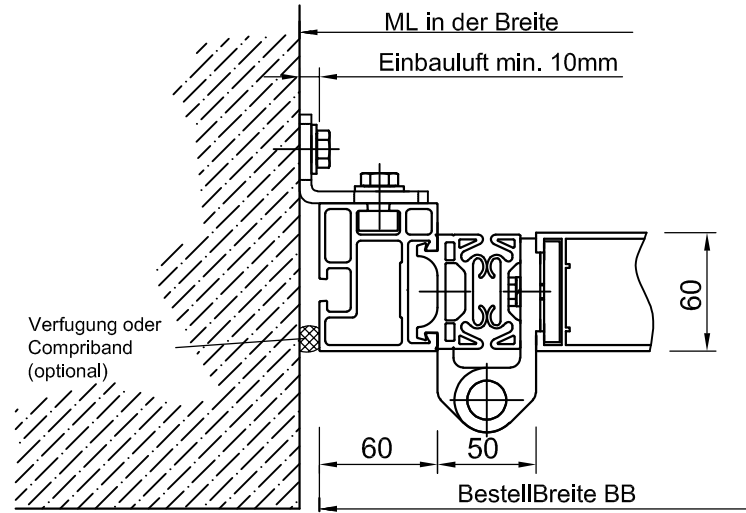

AL603F

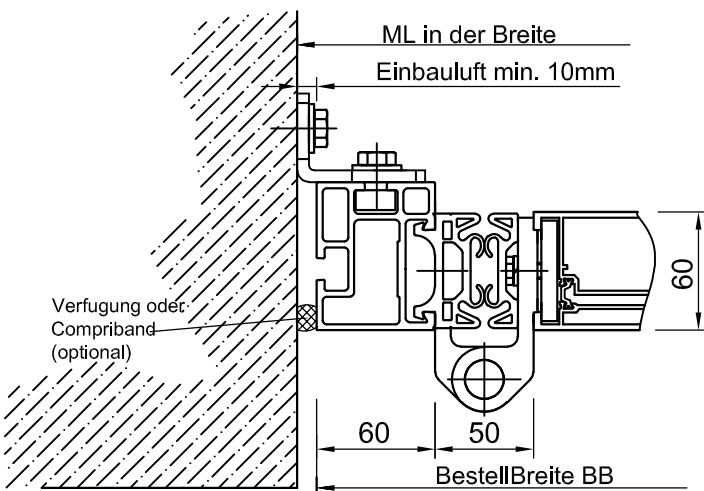

ST602F

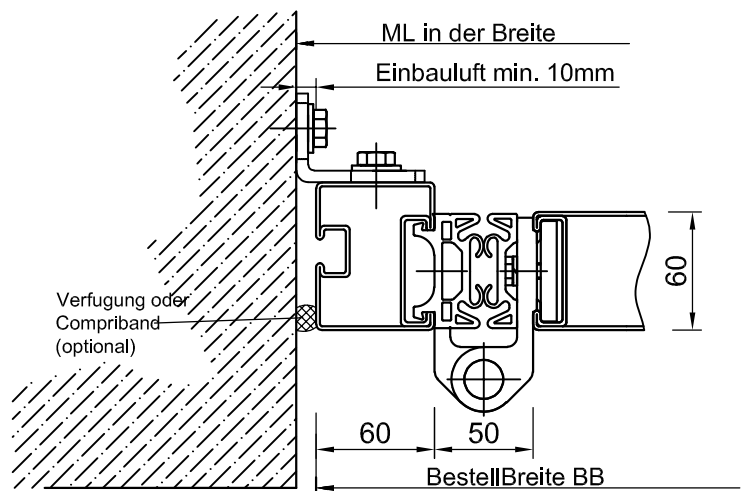

Montageposition Eckleibung seitlich

AL601F 2.0

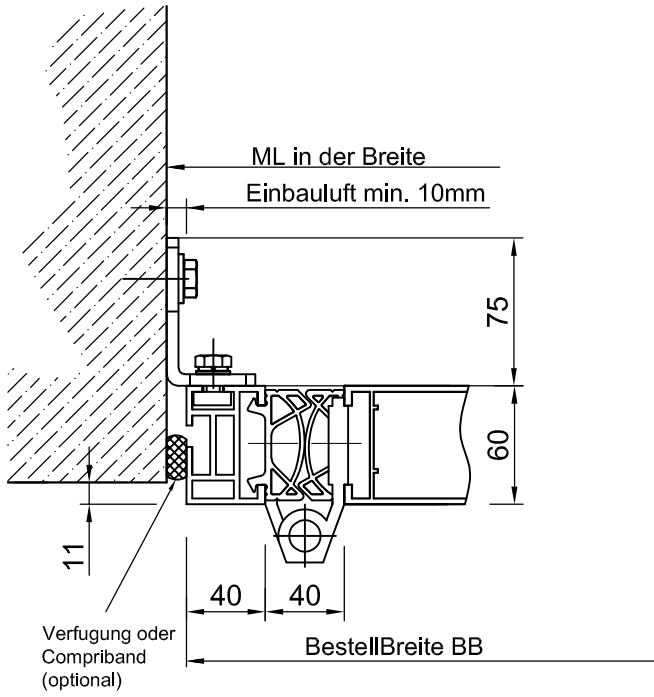

AL602F

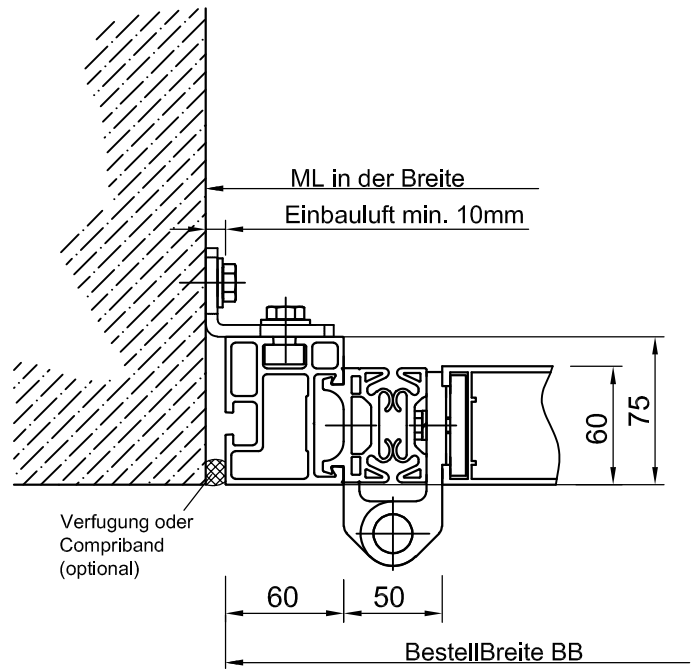

AL603F

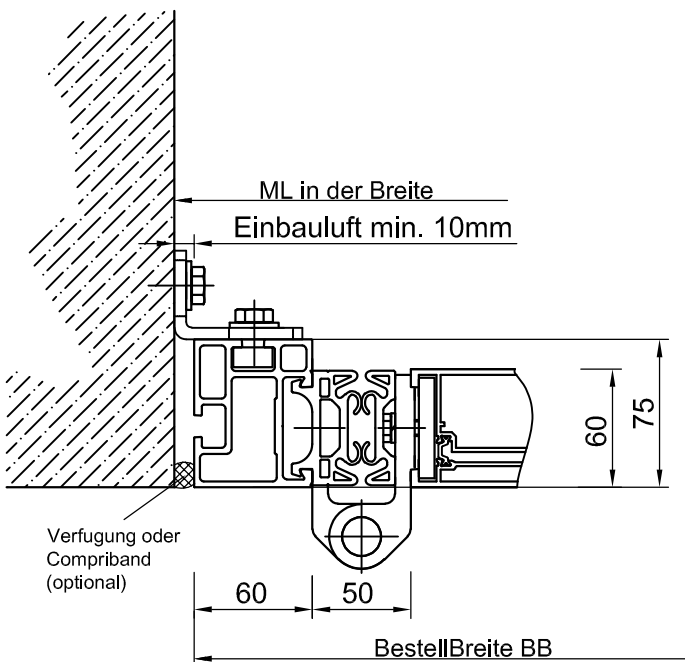

ST602F

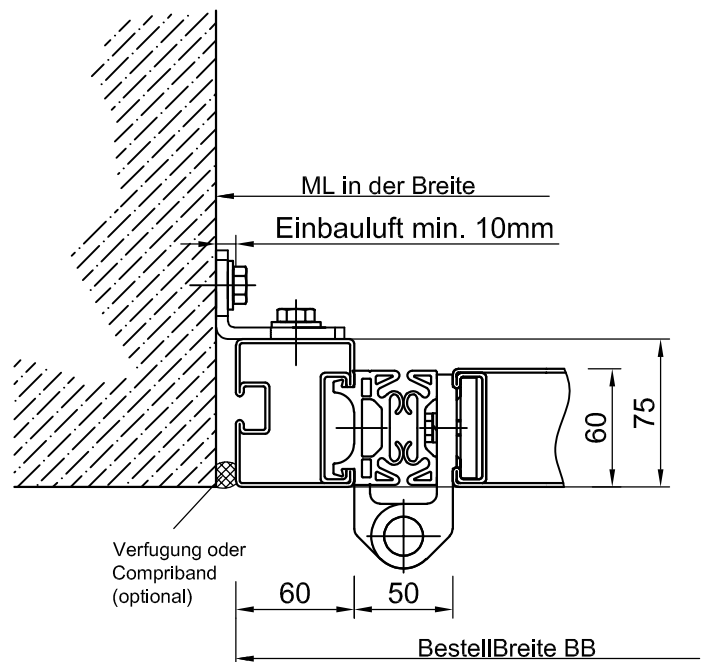

Laufschiene 90 ° vor/hinter der Leibung Sturz mit Verkleidung

AL601F

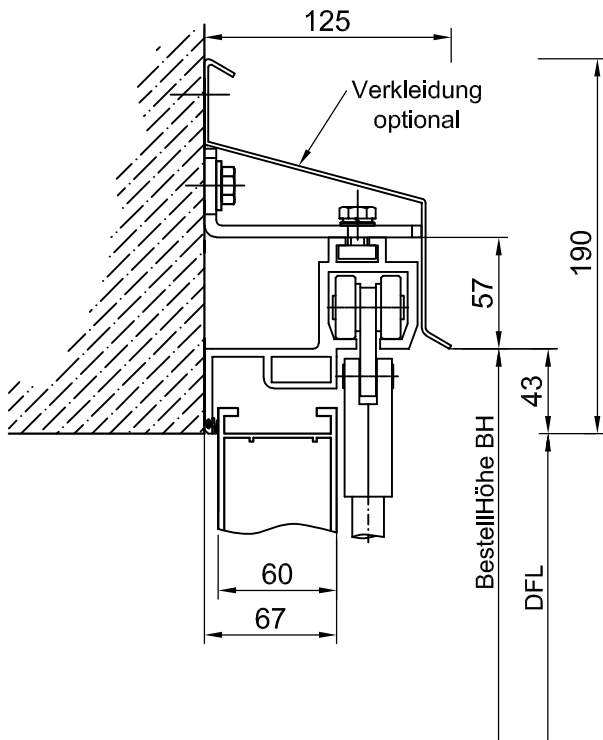

AL602F

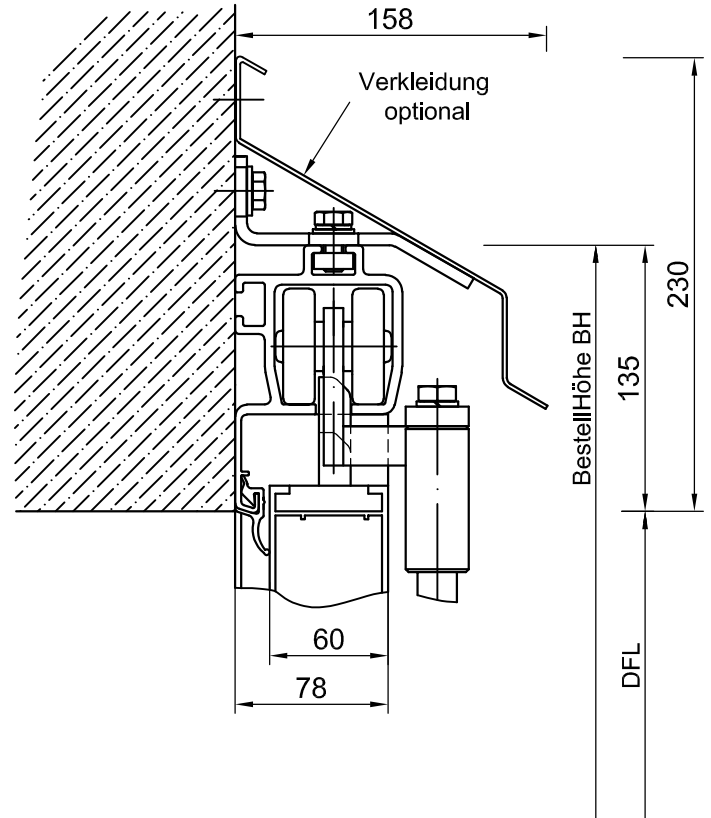

AL603F

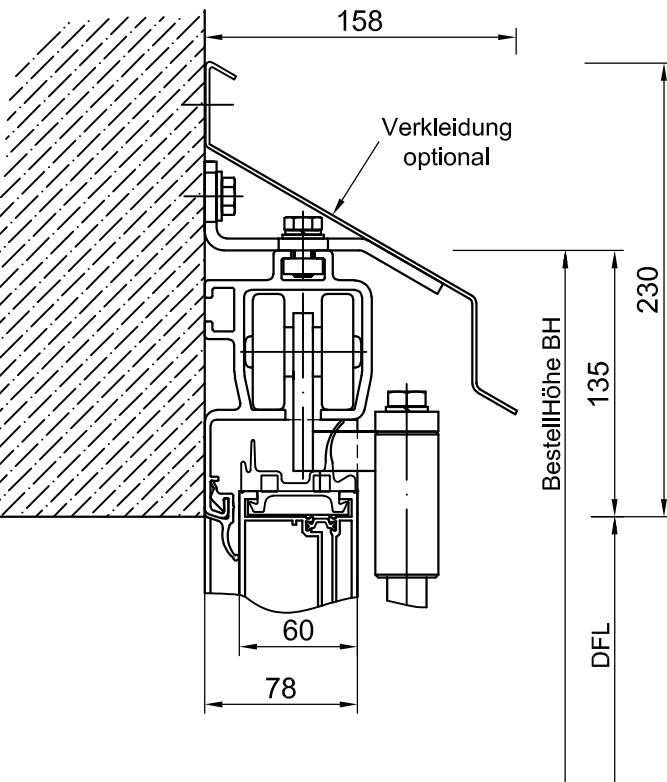

ST602F

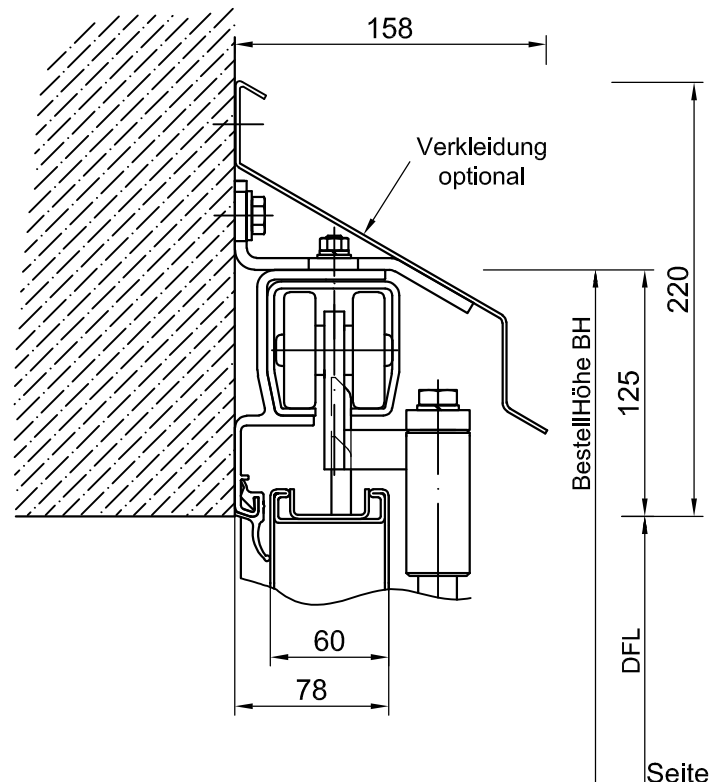

Laufschiene 180 ° (keine durchgehende Bodenführung möglich) vor/hinter der Leibung mit Verkleidung

AL601F 2.0

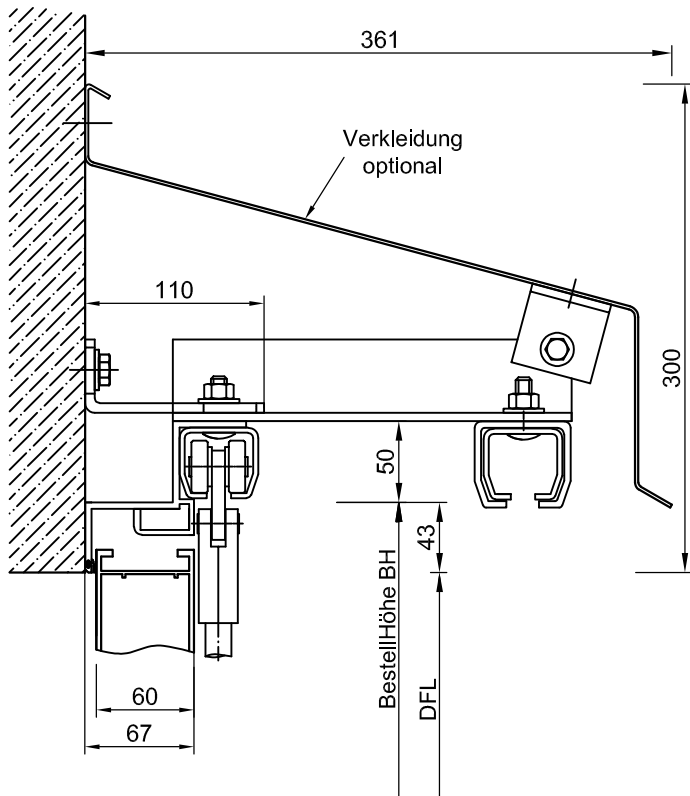

AL602F

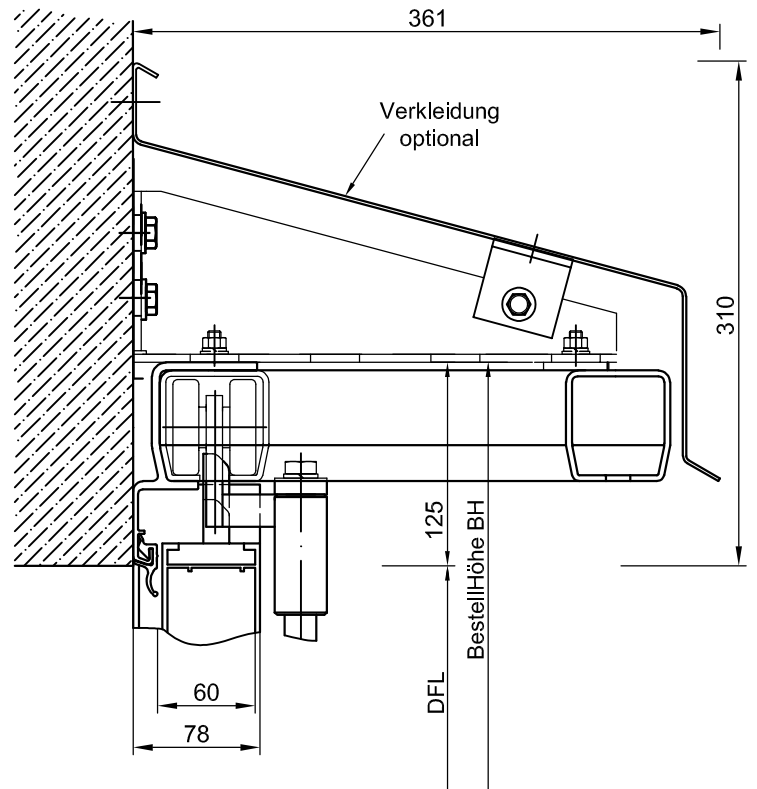

AL603F

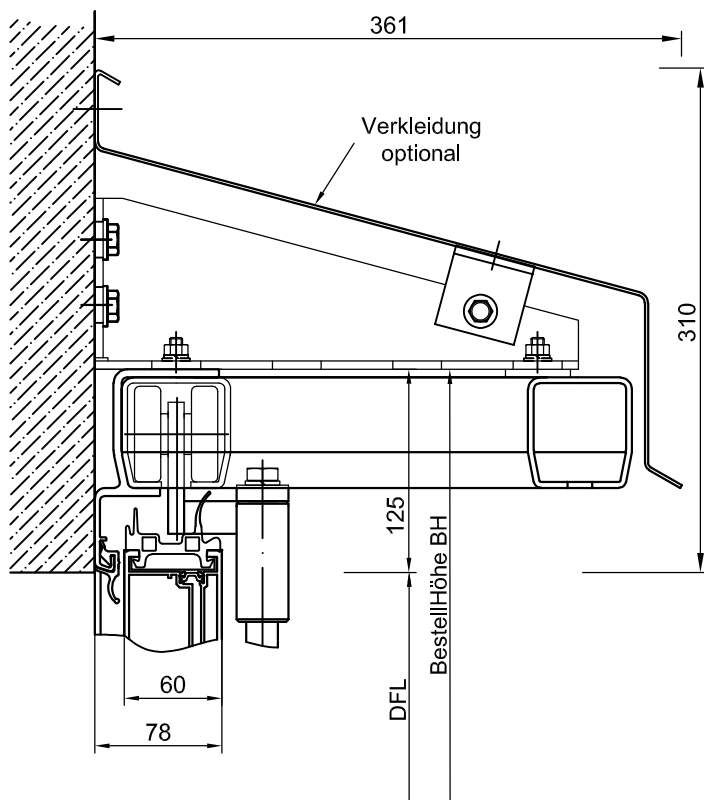

ST602F

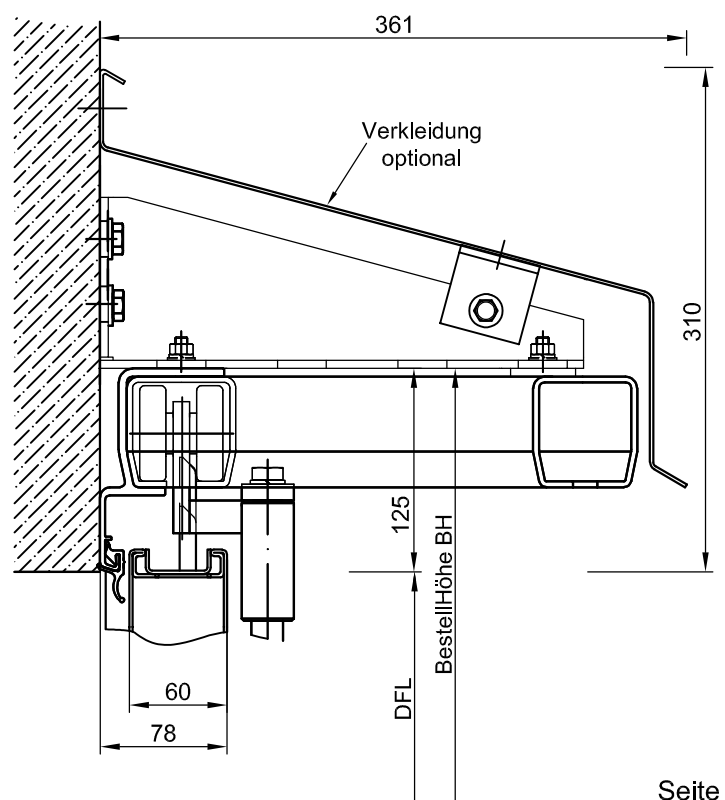

Laufschiene 180 ° (keine durchgehende Bodenführung möglich) Eckklebung mit Verkleidung

AL601F 2.0

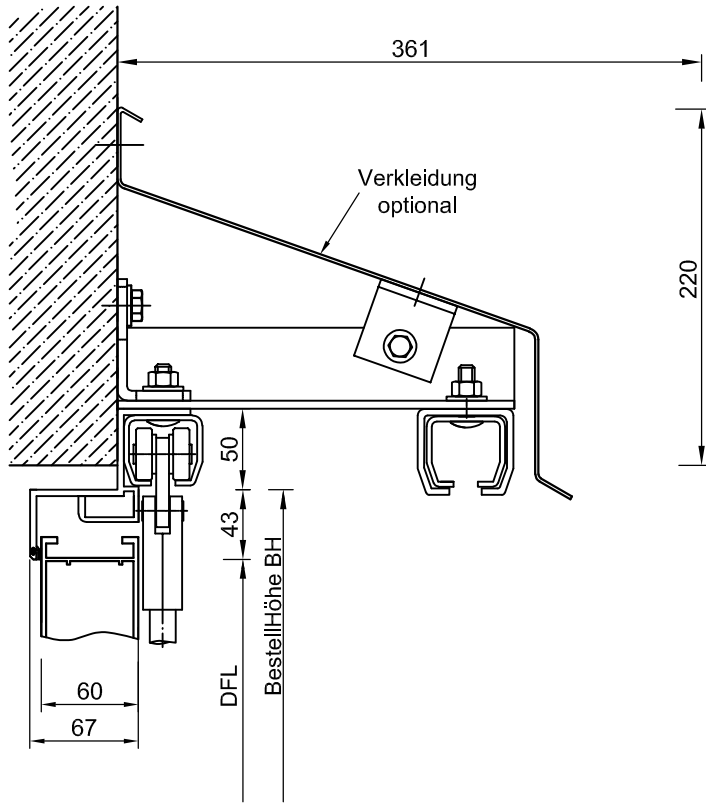

AL602F

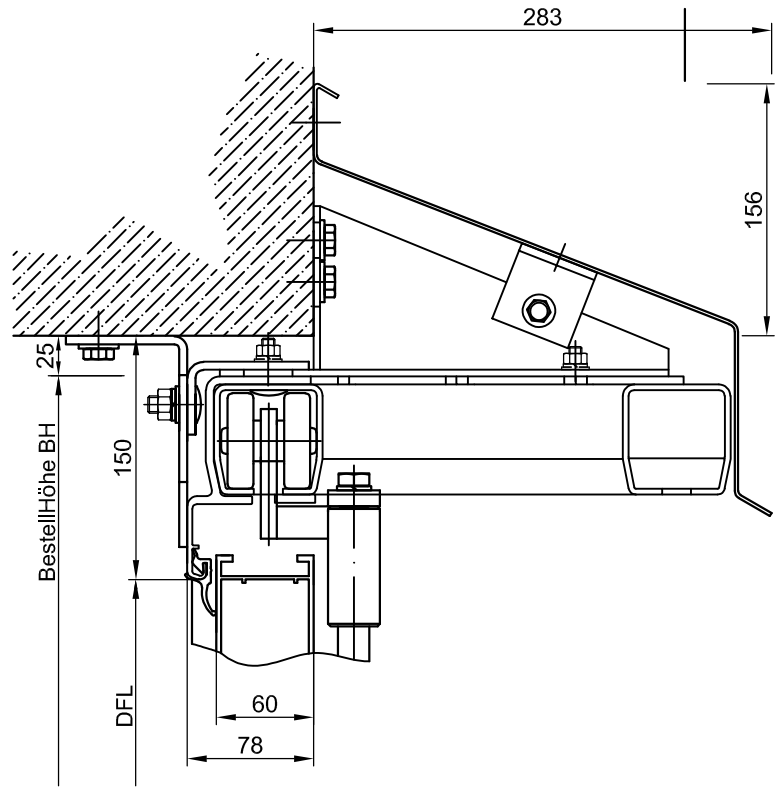

AL603F

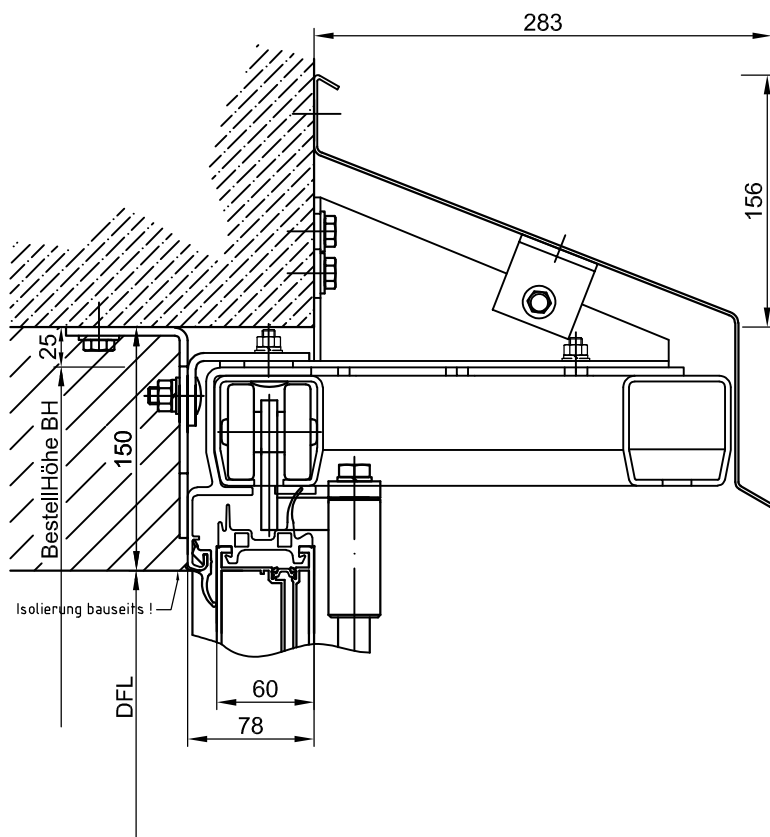

ST602F

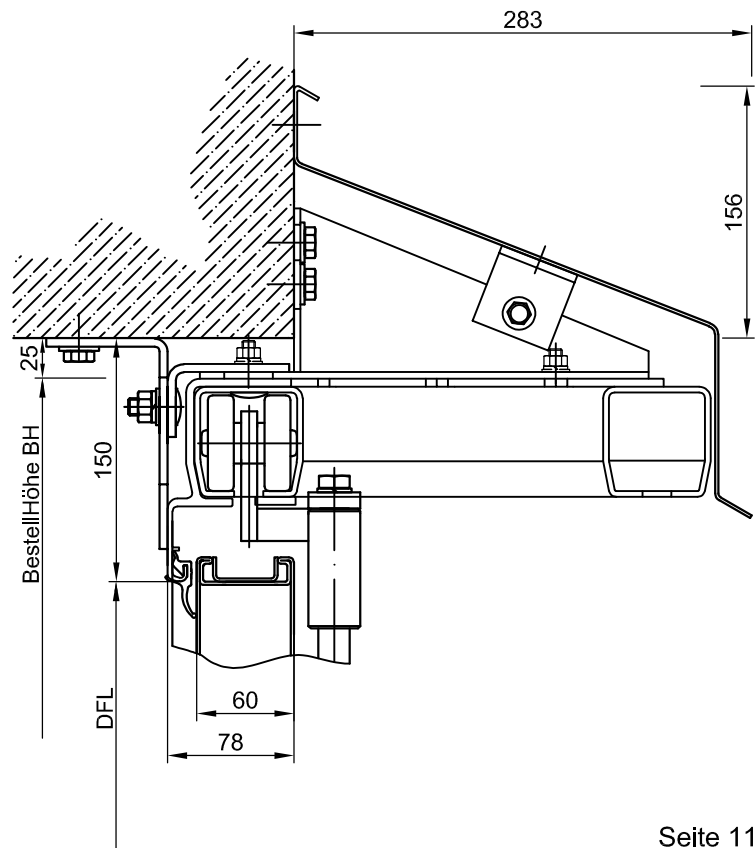

Laufschiene 90 ° Laufschiene verstärkt vor/hinter der Leibung Sturz mit Verkleidung

AL601F

nicht möglich

AL602F

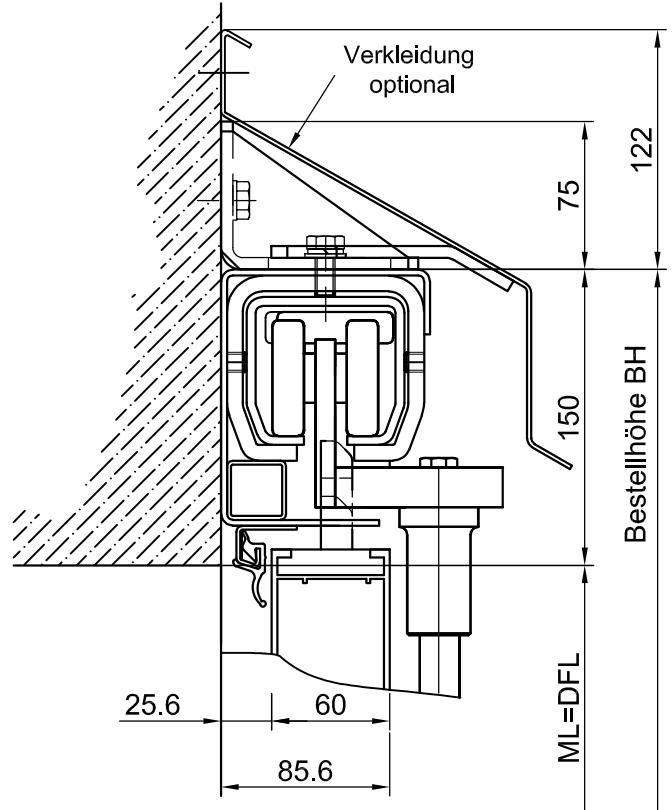

AL603F

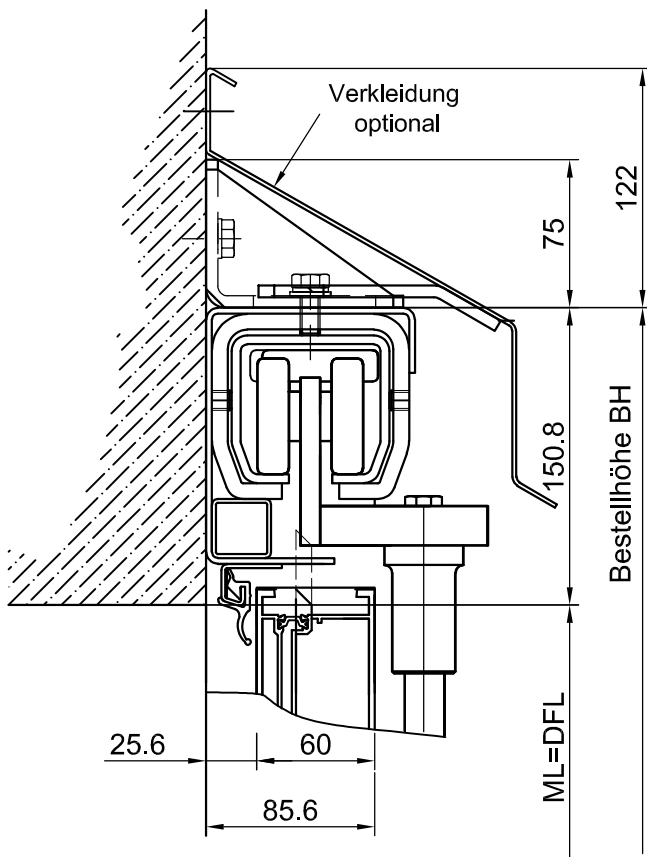

ST602F

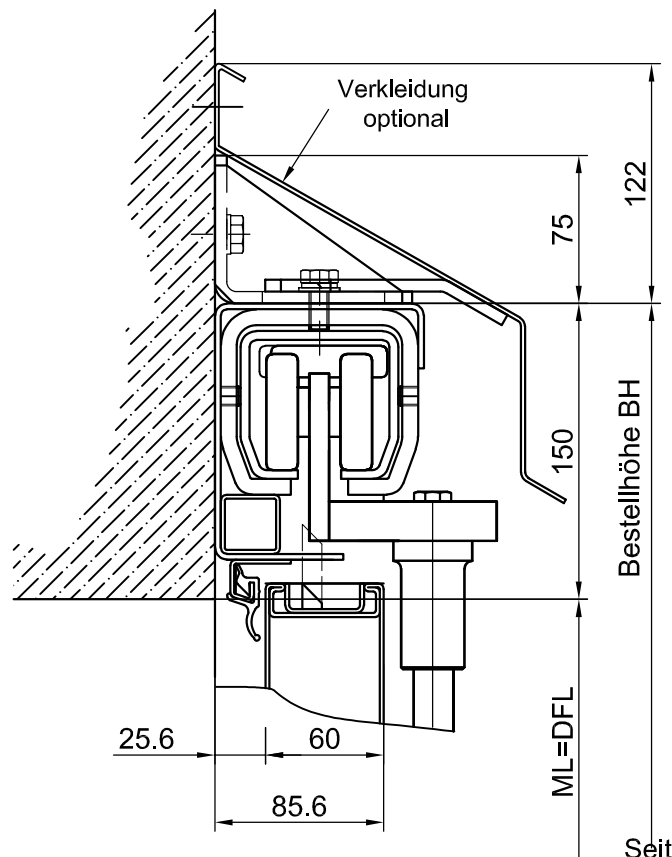

Laufschiene 90 ° Laufschiene verstärkt in der Leibung

AL601F

nicht möglich

AL602F

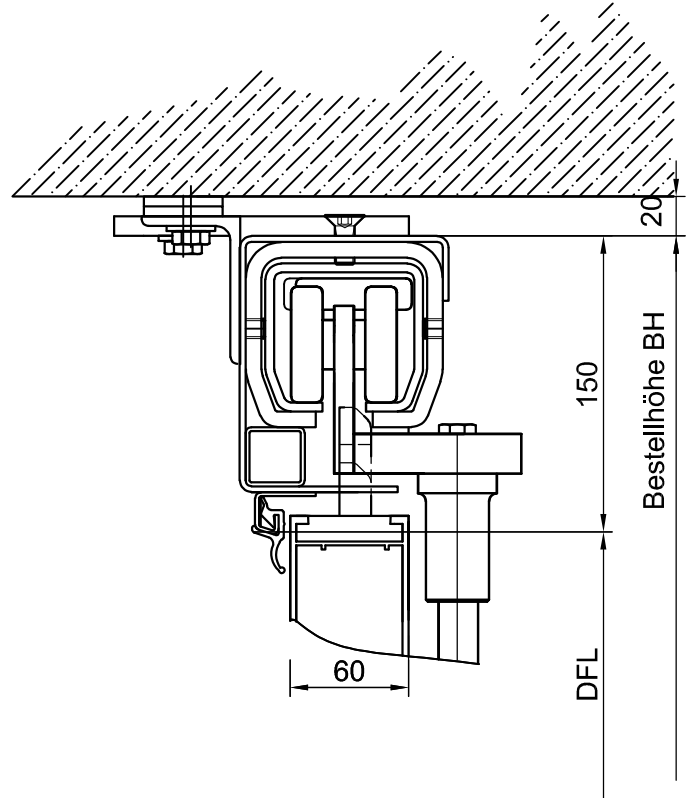

AL603F

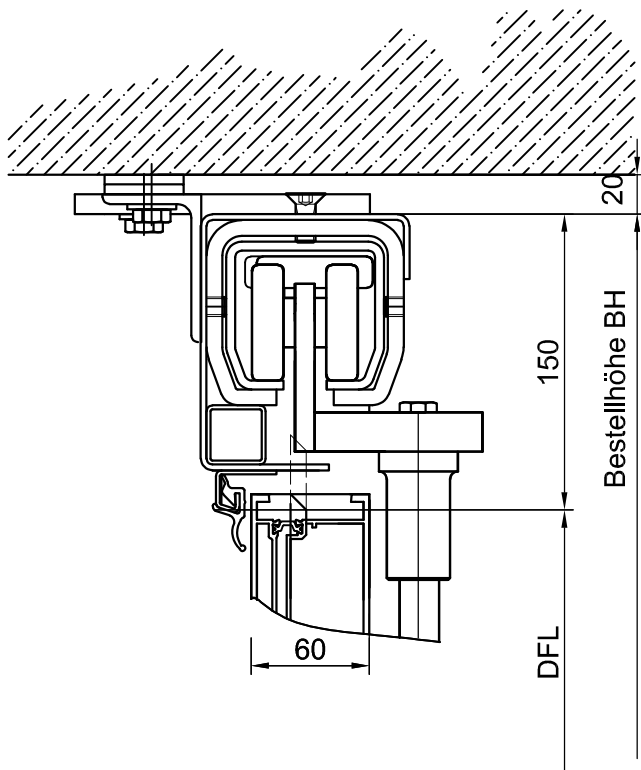

ST602F

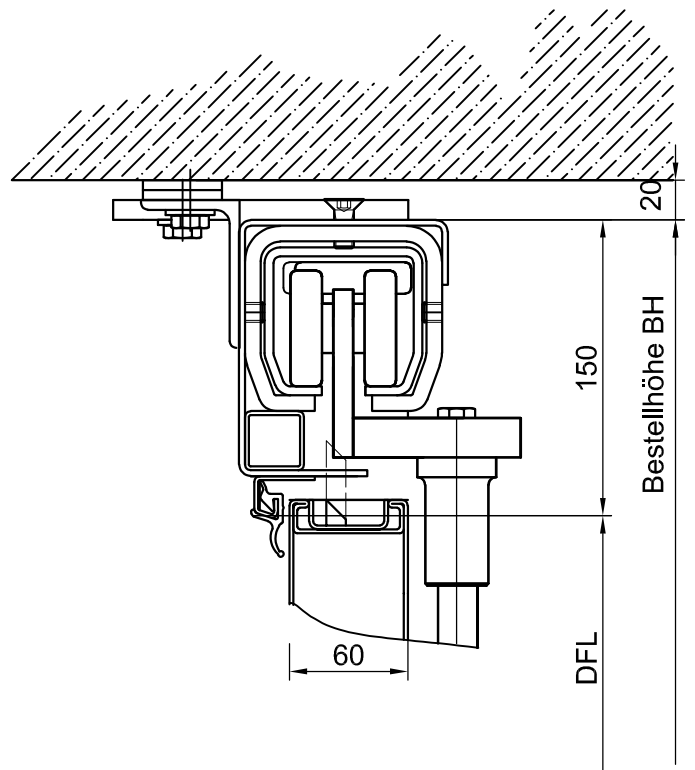

Bodenabschluss

Schwelle Anschlagwinkel L50

ACHTUNG: 5% Gefälle in Öffnungsrichtung

AL601F 2.0

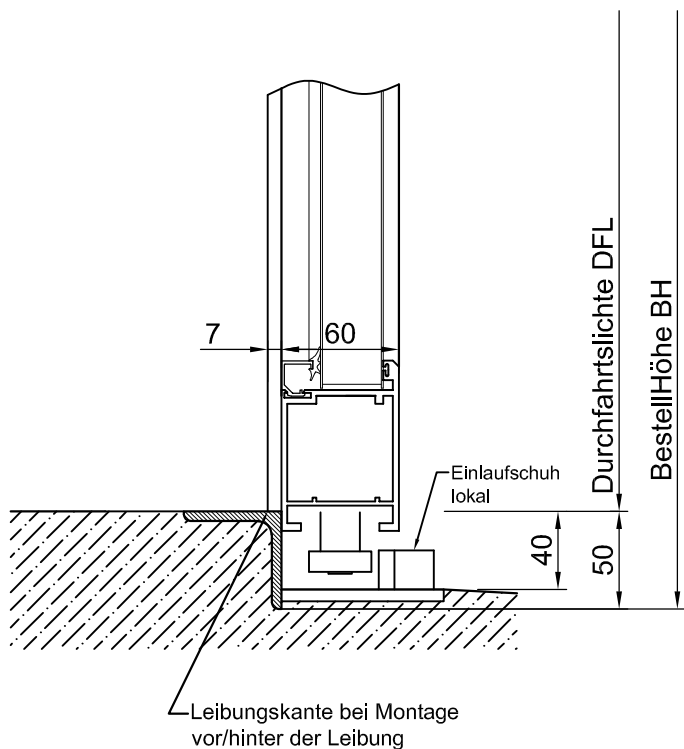

AL602F

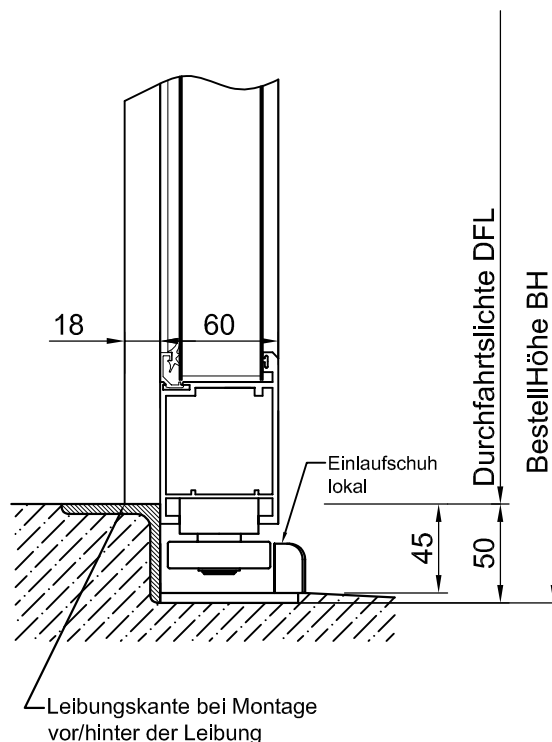

AL603F

nicht möglich

ST602F

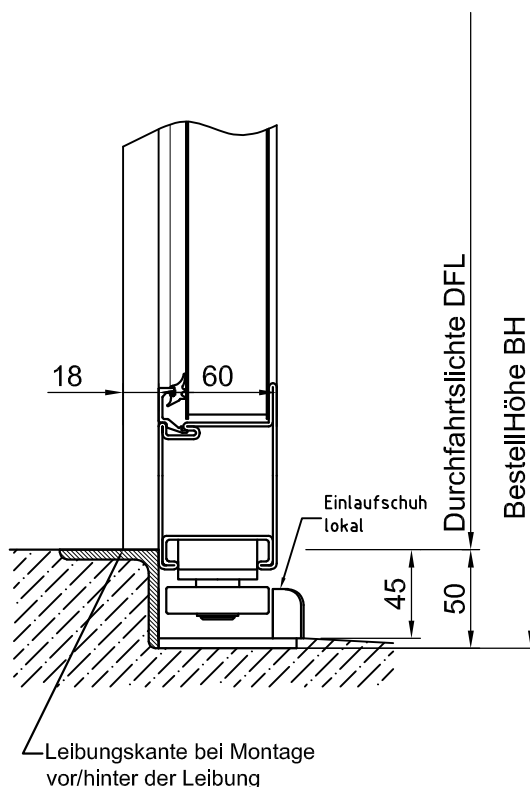

Bodenabschluss Schwelle L50D

ACHTUNG: 5% Gefälle in Öffnungsrichtung

AL601F 2.0

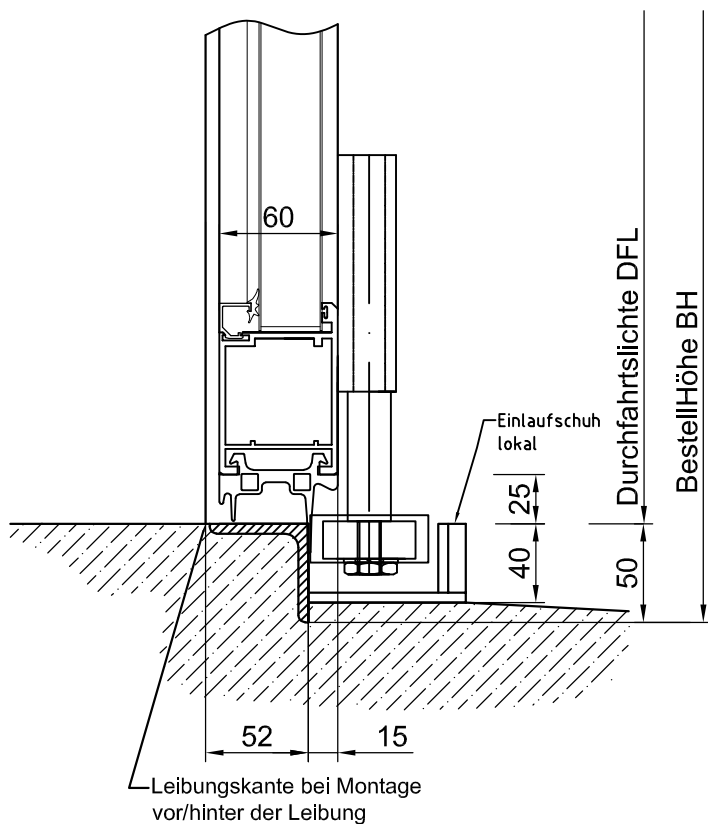

AL602F

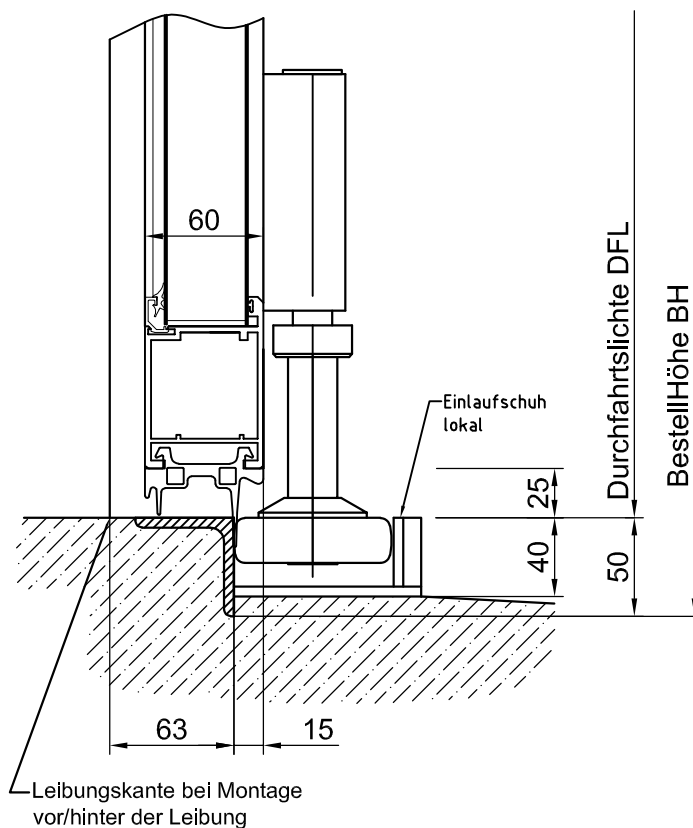

AL603F

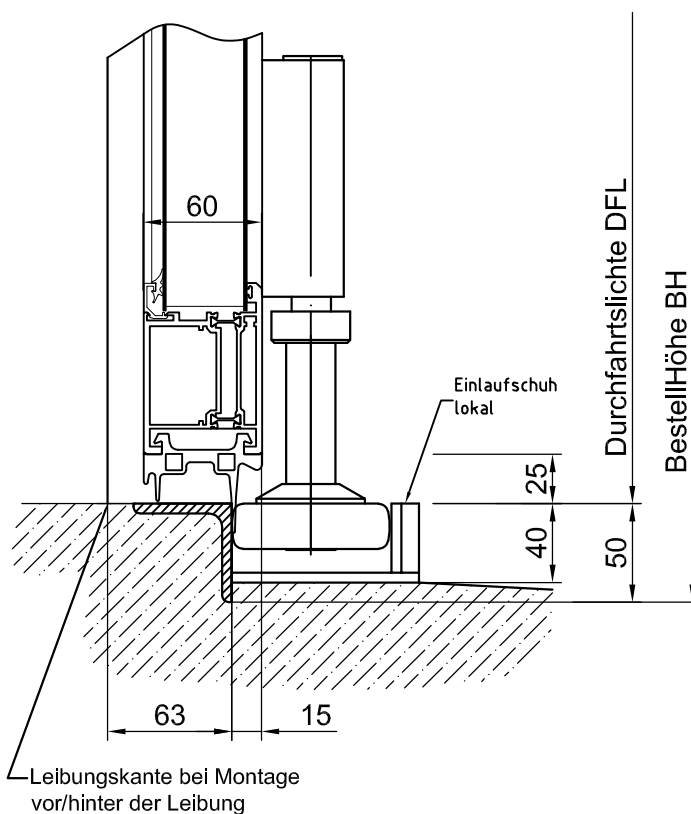

ST602F

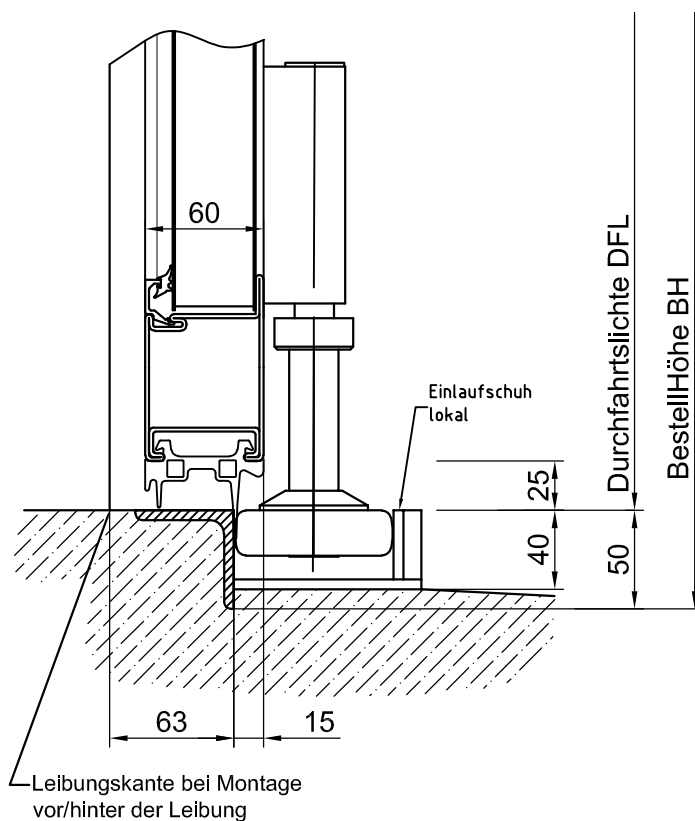

Bodenabschluss Schwelle U50D

ACHTUNG: 5% Gefälle in Öffnungsrichtung

AL601F 2.0

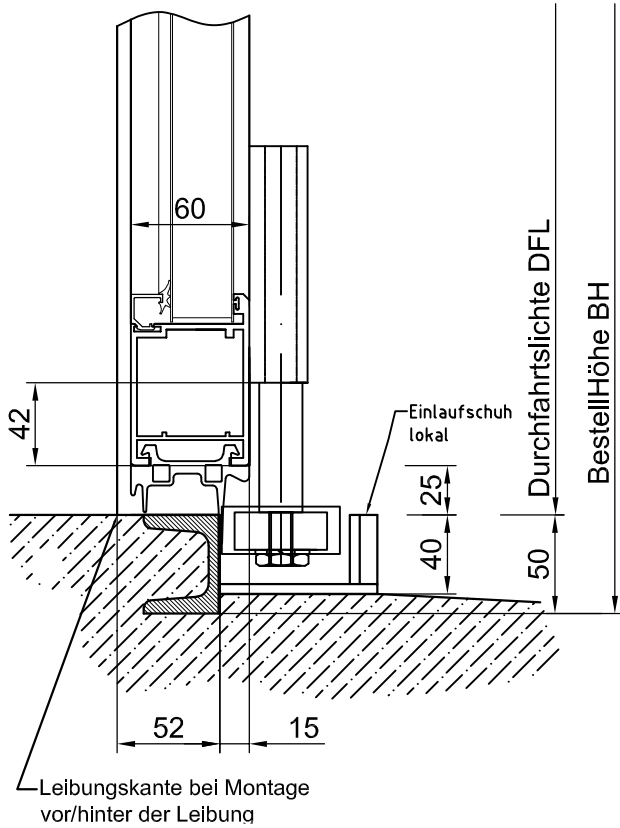

AL602F

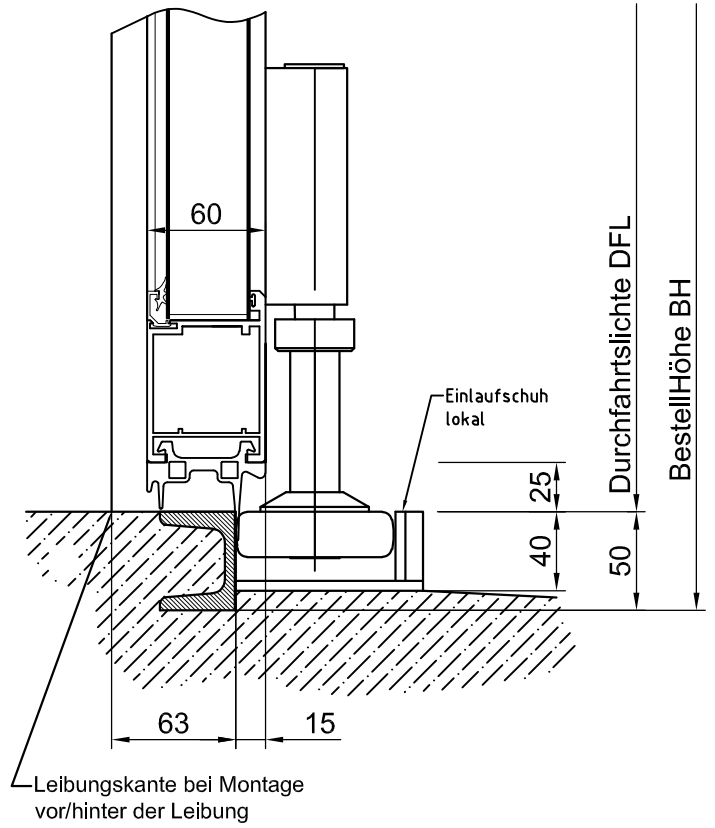

AL603F

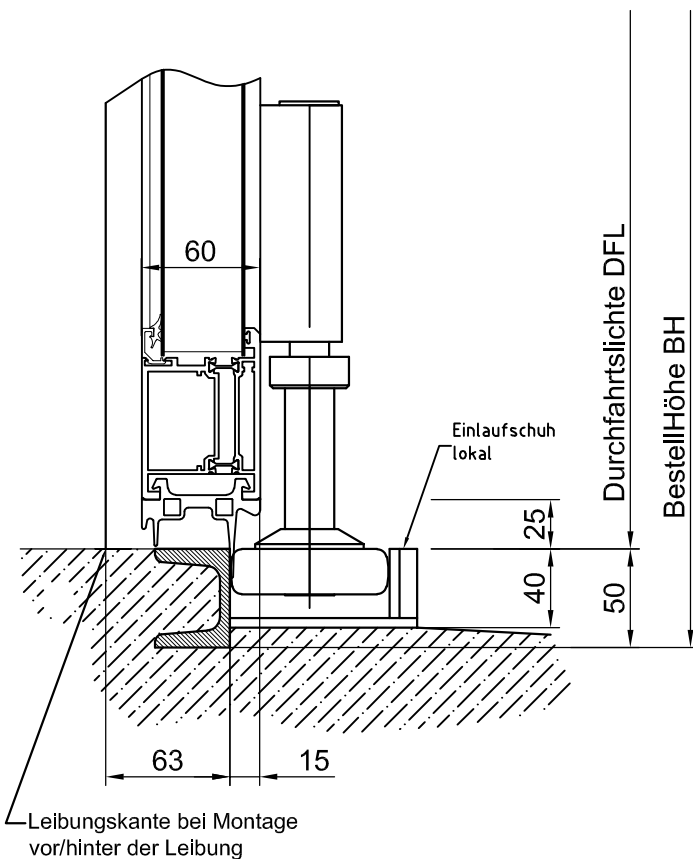

ST602F

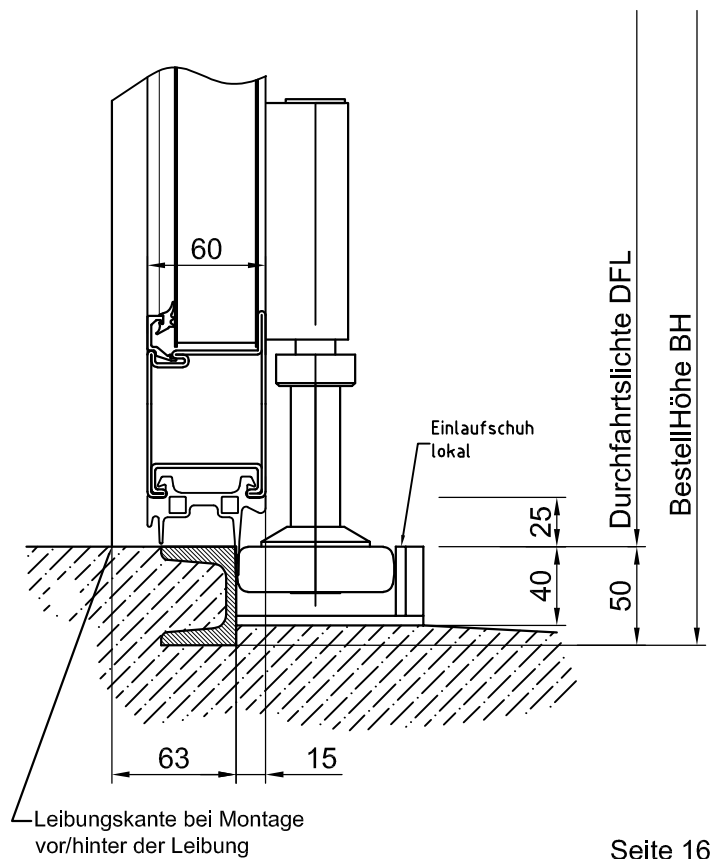

Bodenabschluss Schwelle Doppelanschlag DA

ACHTUNG: 5% Gefälle in Öffnungsrichtung

AL601F 2,0

AL602F

nicht möglich

nicht möglich

AL603F

ST602F

nicht möglich

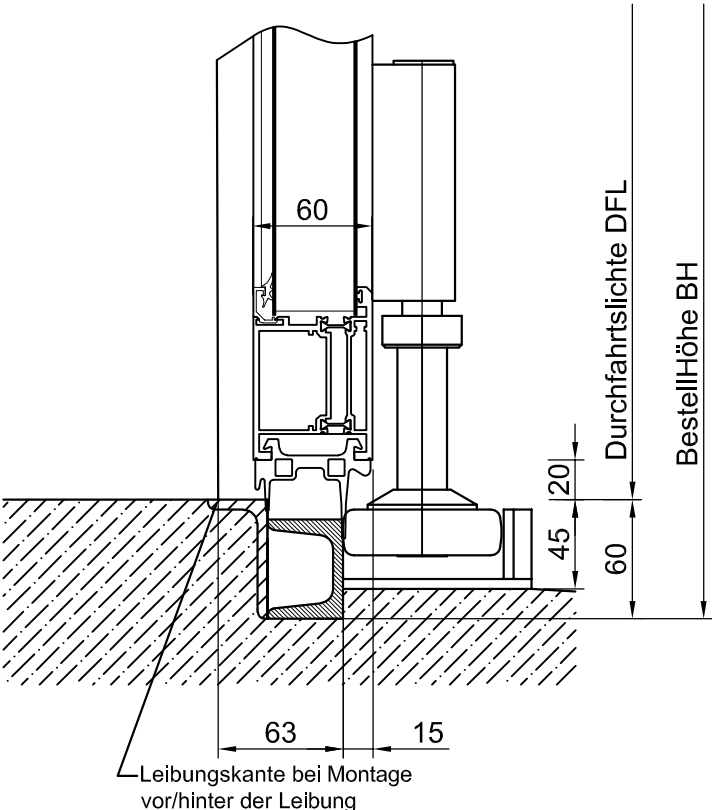

Bodenabschluss

Flachstahlschwelle S10D/S20D

ACHTUNG: 5% Gefälle in Öffnungsrichtung

AL601F

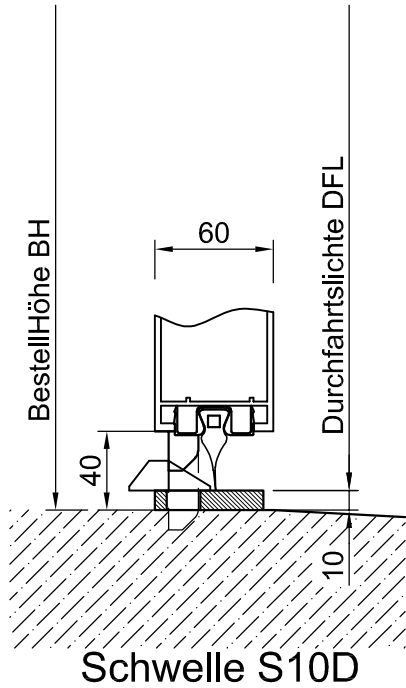

AL602F

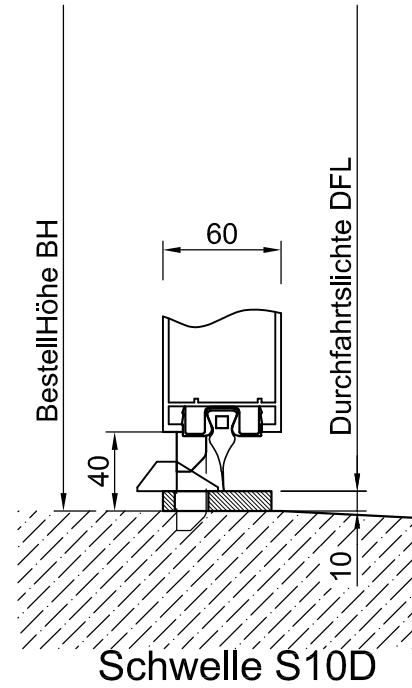

AL603F

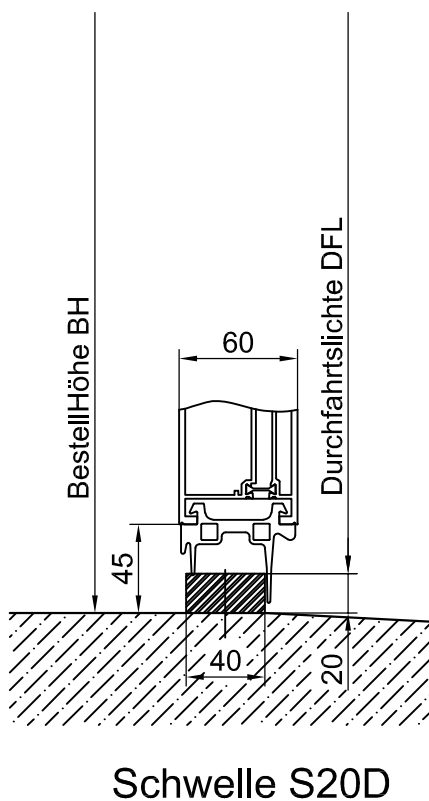

ST602F

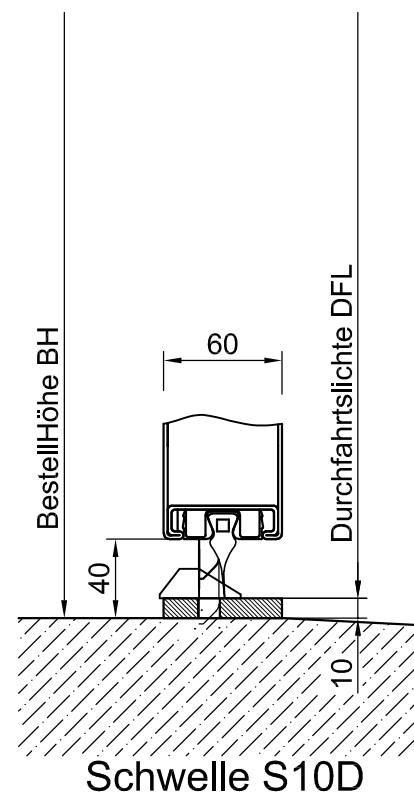

Bodenabschluss

Schwellenlos Riegelanschlag RA

ACHTUNG: 5% Gefälle in Öffnungsrichtung

AL601F 2.0

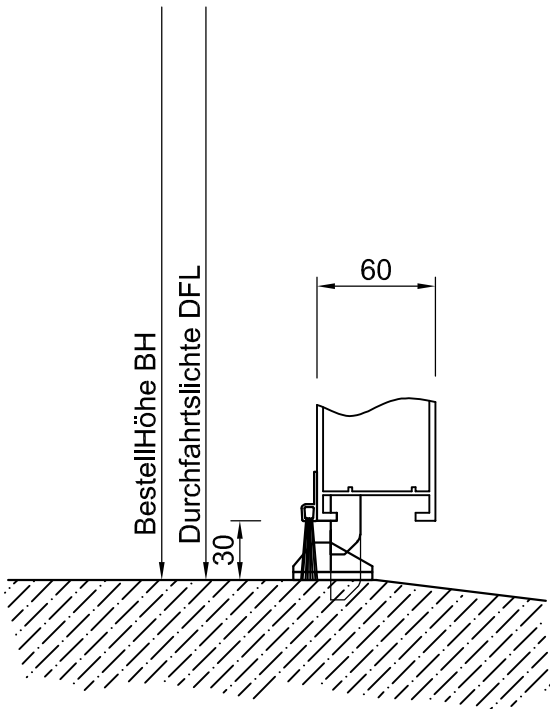

AL602F

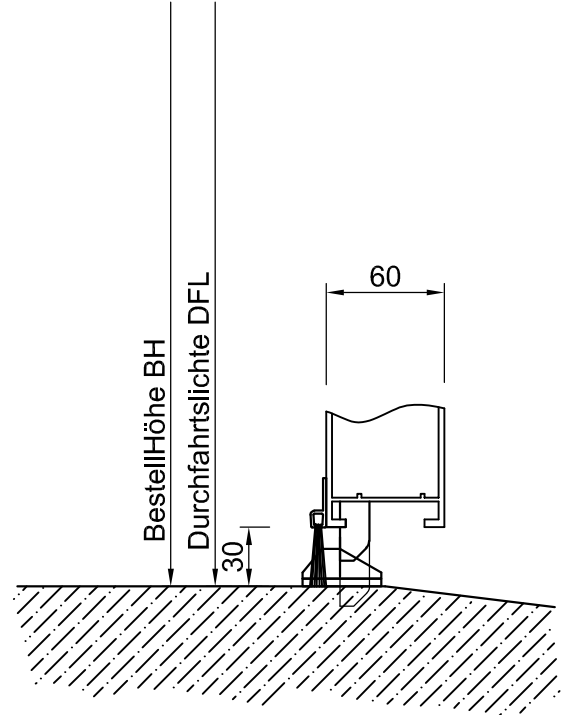

AL603F

nicht möglich

ST602F

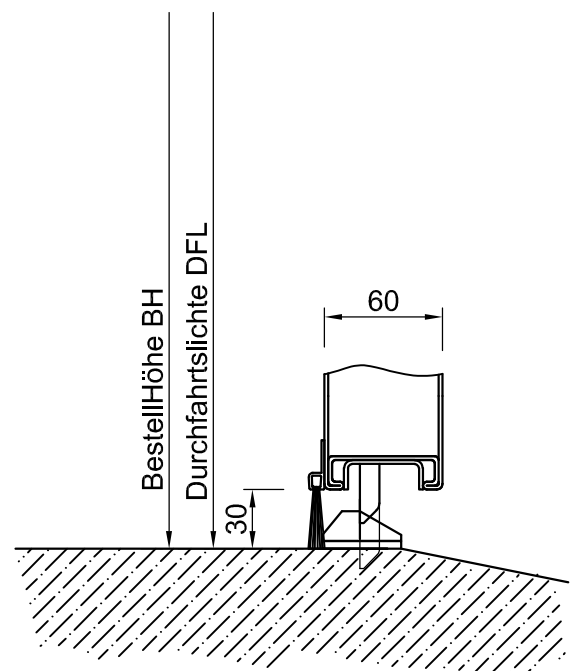

Bodenabschluss Bodenführung BF

ACHTUNG: 5% Gefälle in Öffnungsrichtung

AL601F 2.0

nicht möglich

AL602F

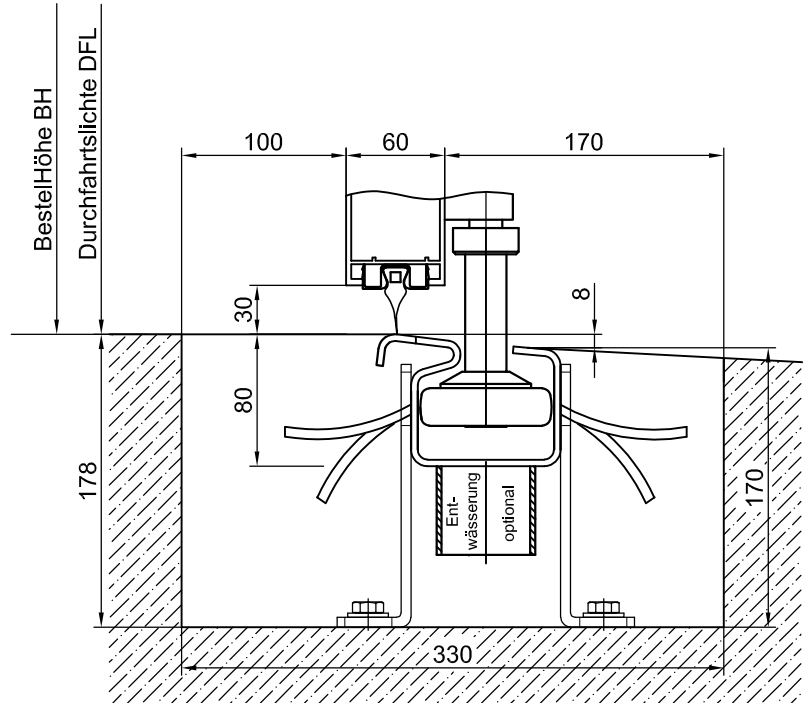

AL603F

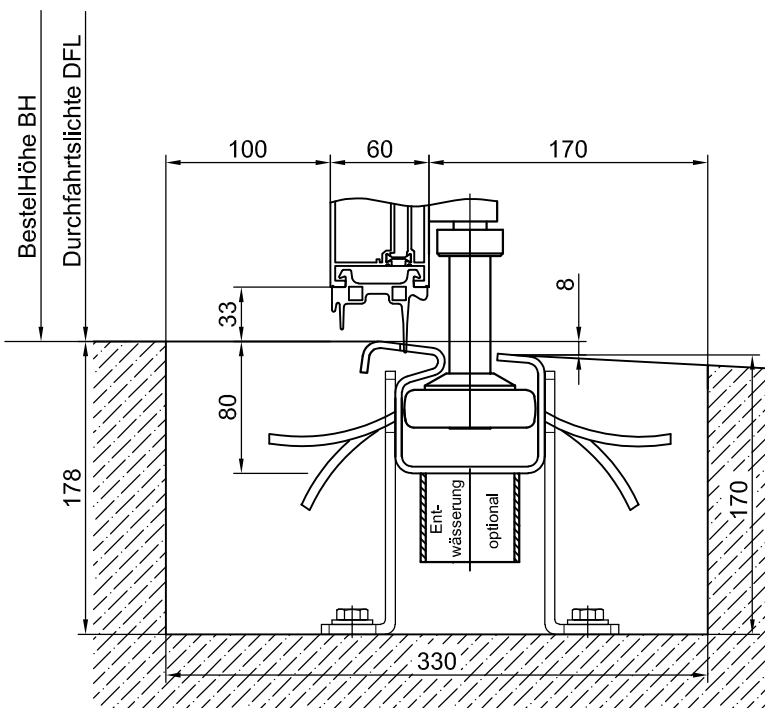

ST602F

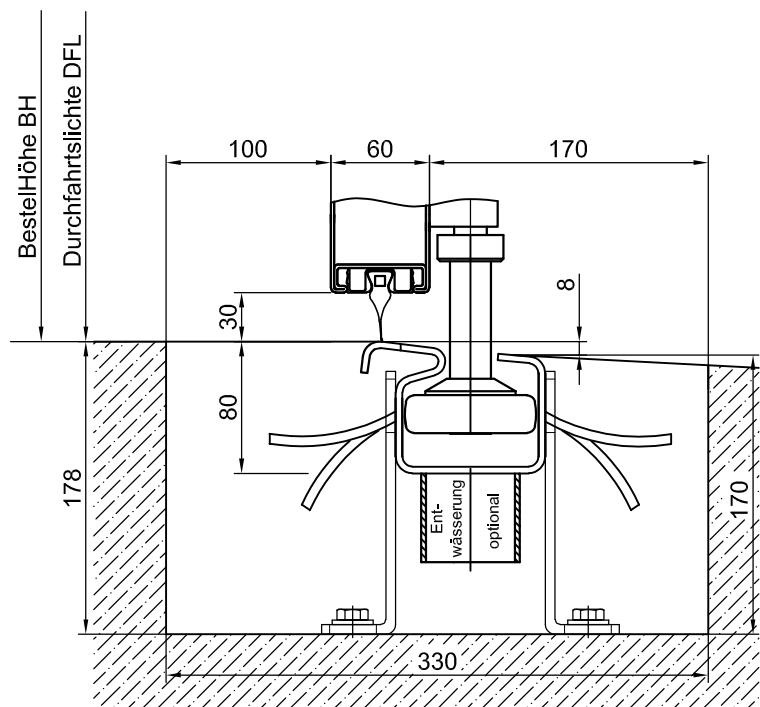

Bodenabschluss

Bodenführung beheizt BF bhz.

ACHTUNG: 5% Gefälle in Öffnungsrichtung

AL601F 2.0

nicht möglich

AL602F

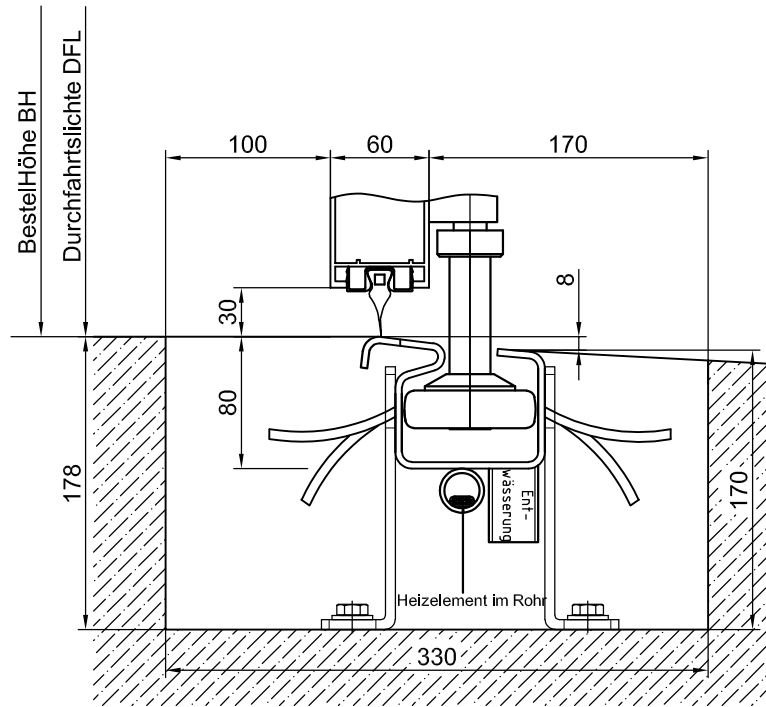

AL603F

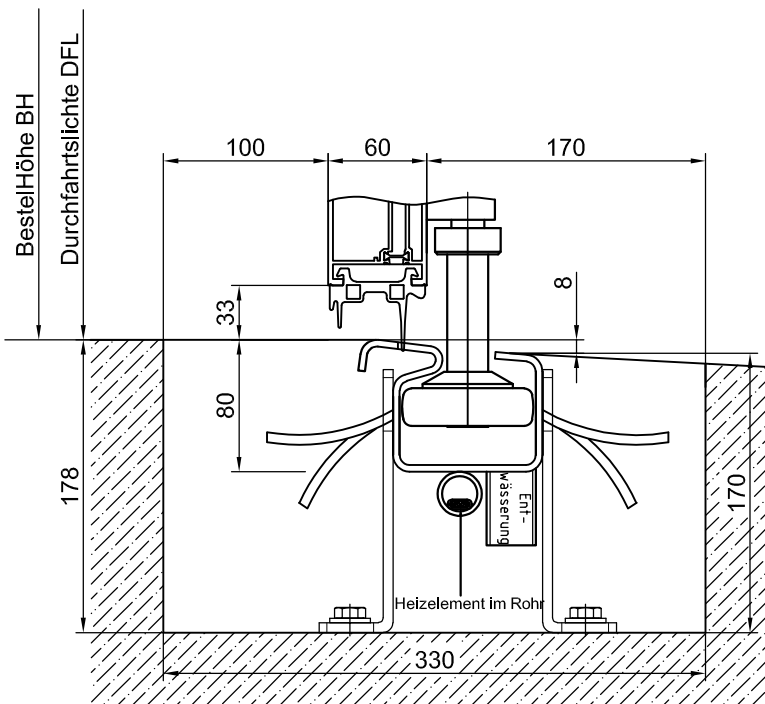

ST602F

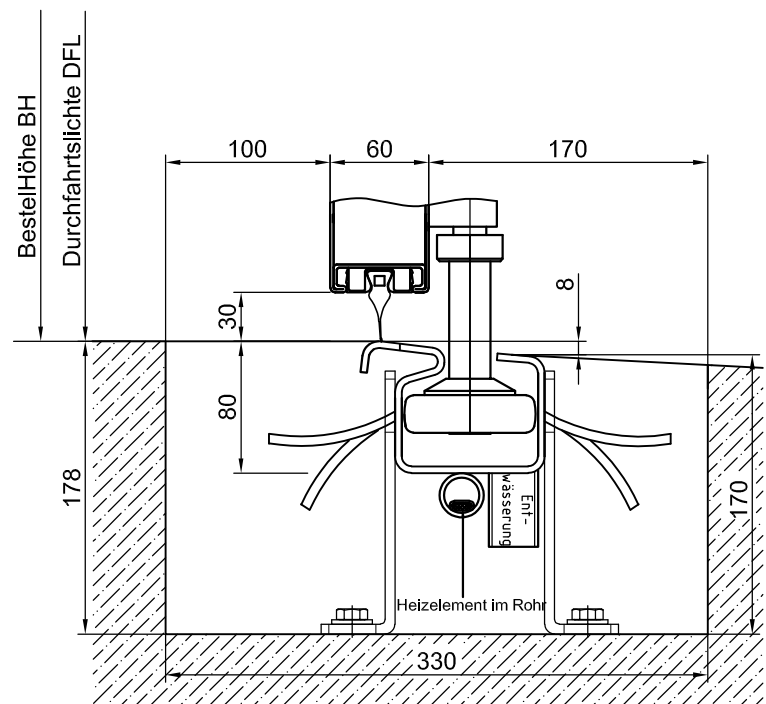

Bodenführung BF-light NIRO

ACHTUNG: 5% Gefälle in Öffnungsrichtung

AL601F 2.0

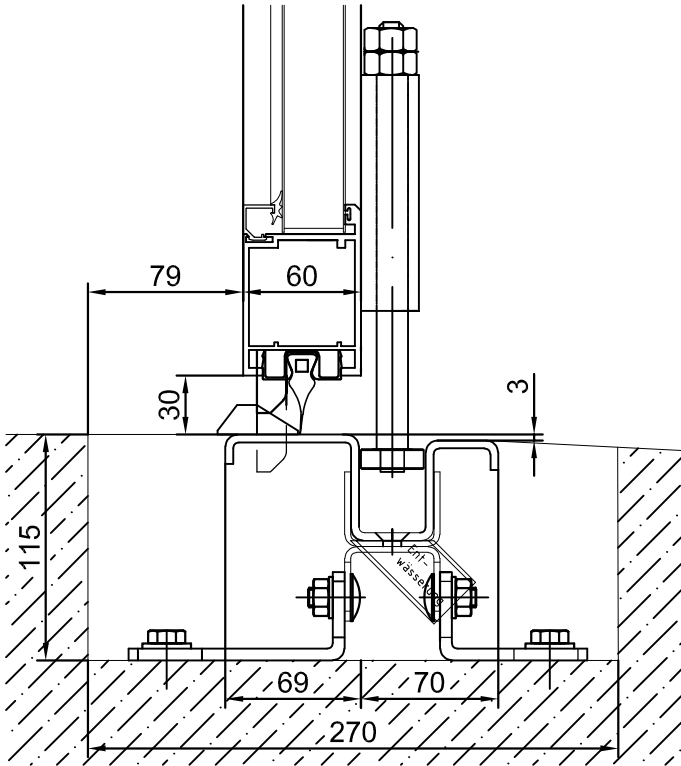

AL602F

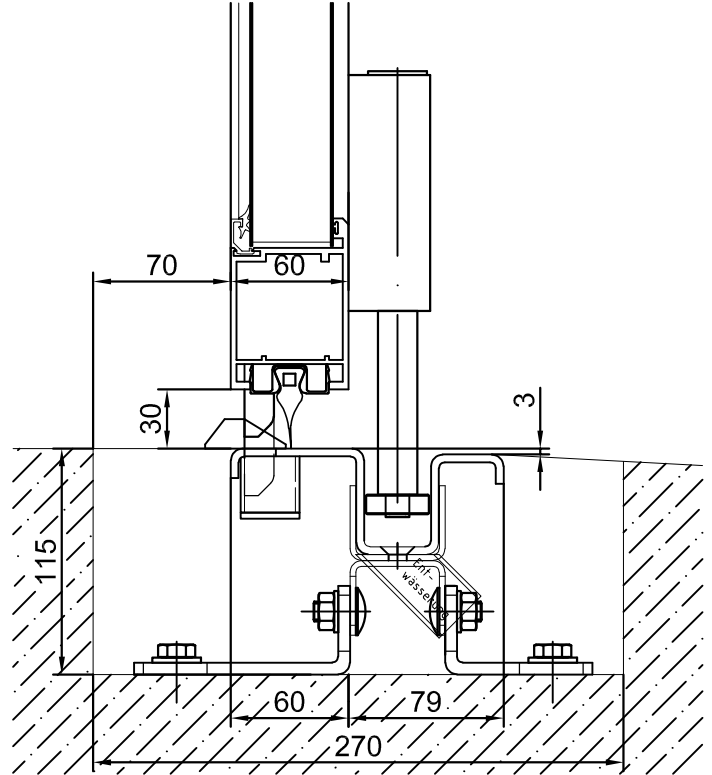

AL603F

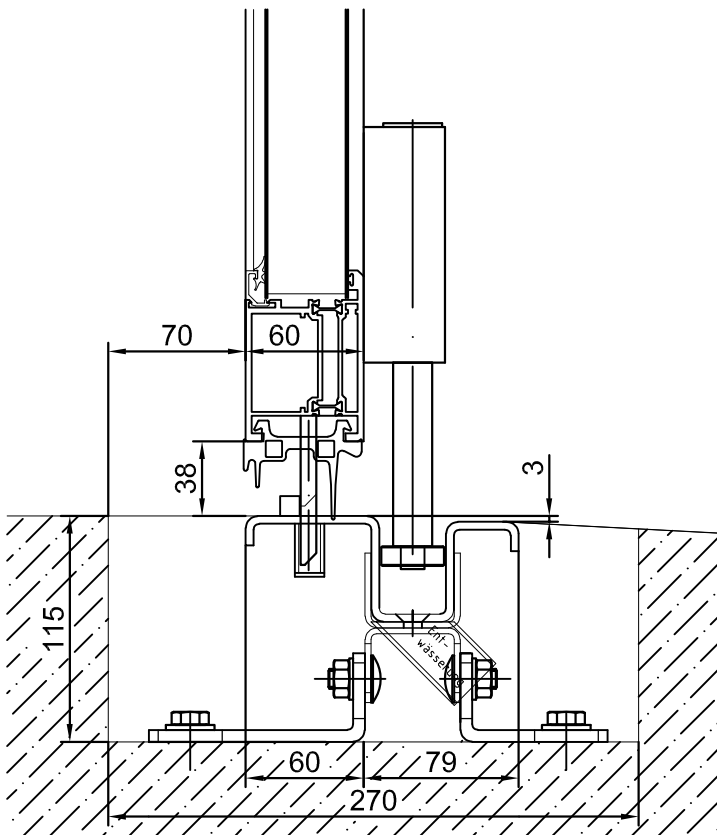

ST602F

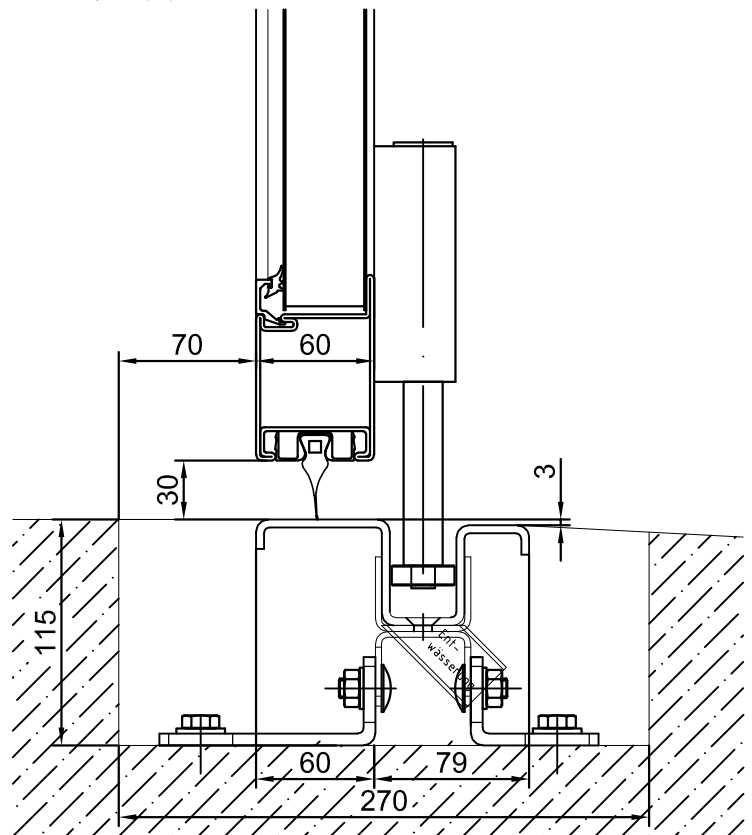

Bodenabschluss

Bodenführung beheizt BF-light NIRO bhz

ACHTUNG: 5% Gefälle in Öffnungsrichtung

AL601F 2.0

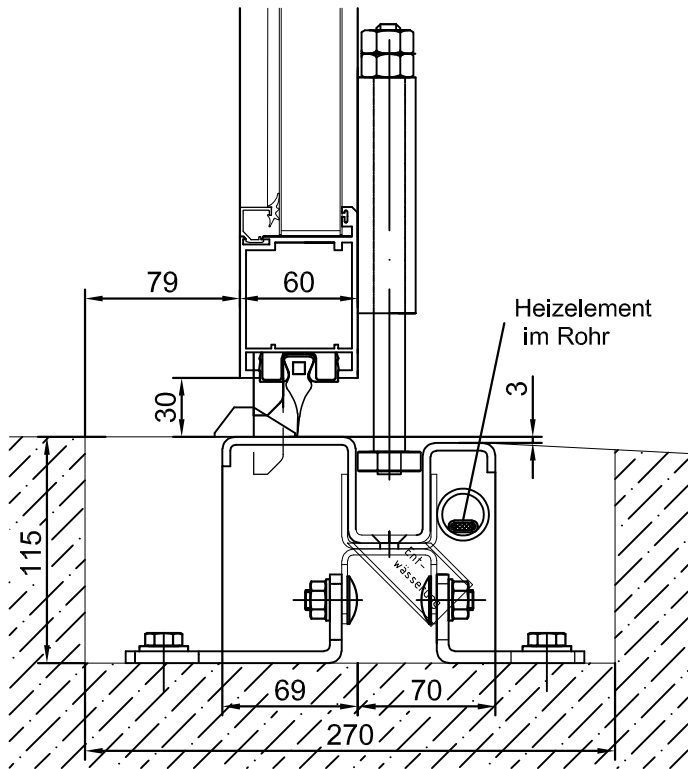

AL602F

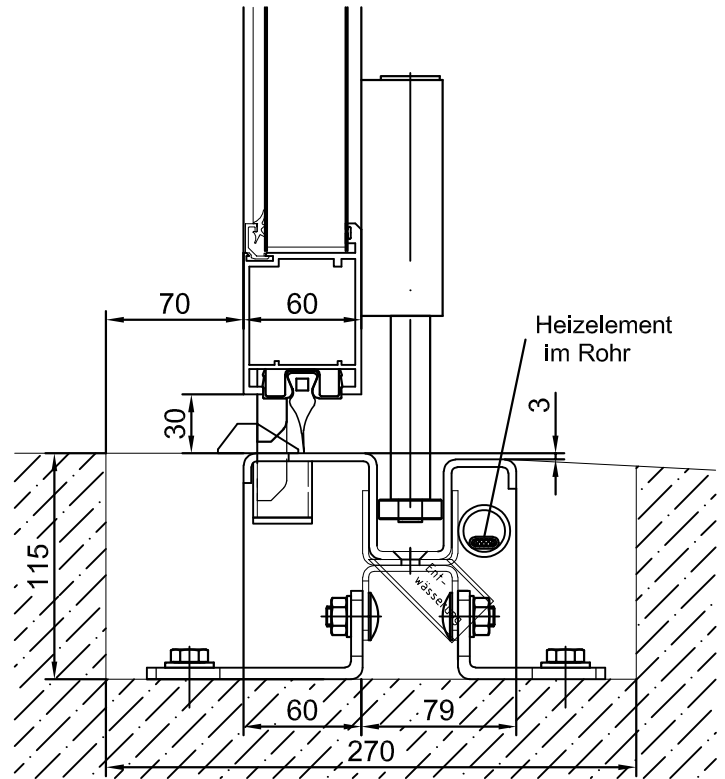

AL603F

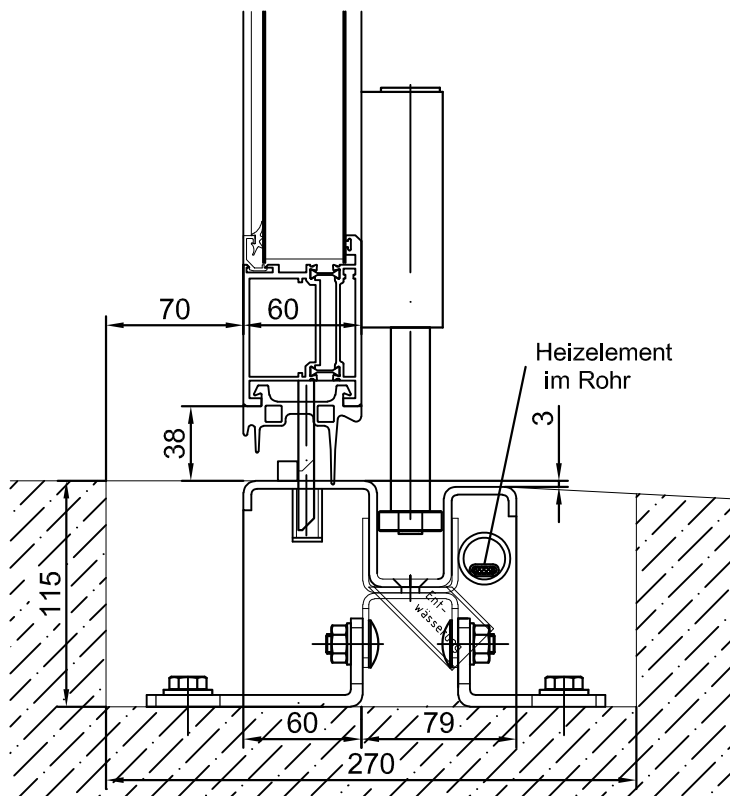

ST602F

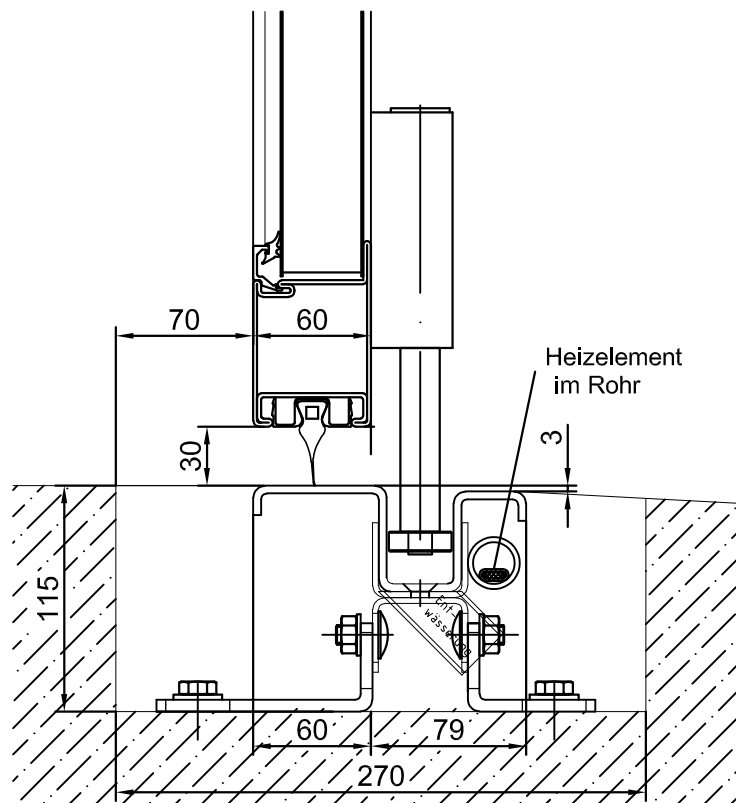

Vertikal und Horizontalschnitt

AL601F 2.0

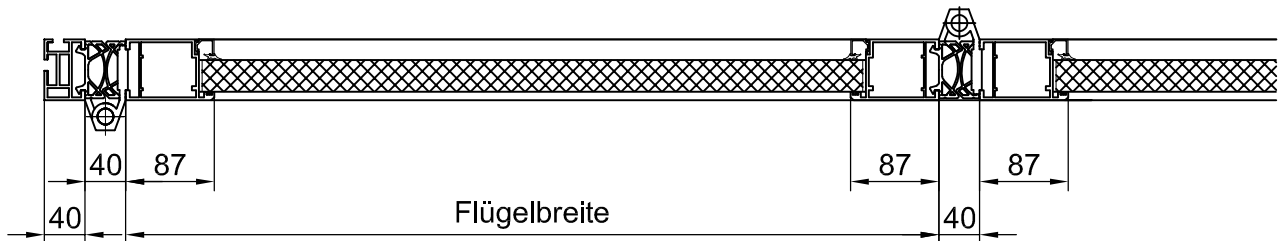
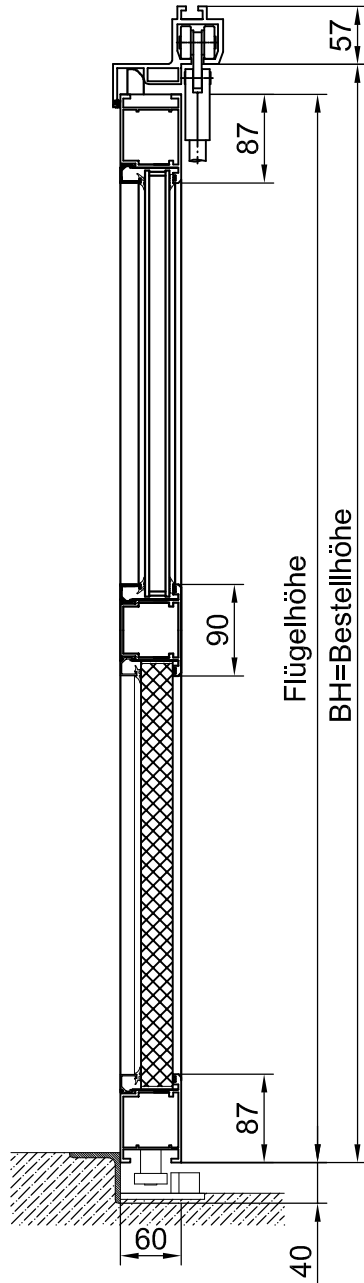

Vertikal und Horizontalschnitt

AL602F

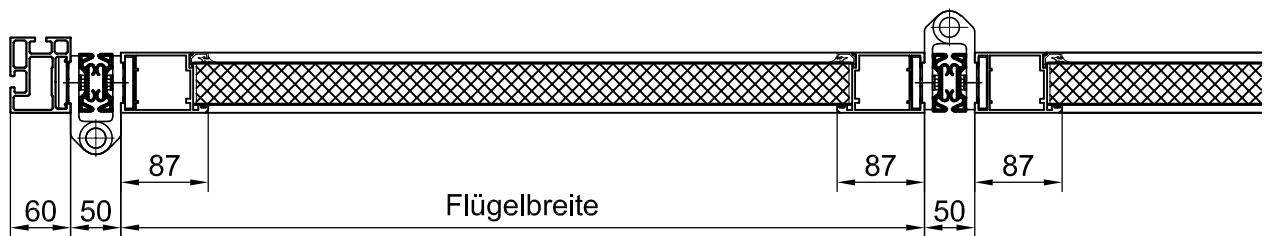
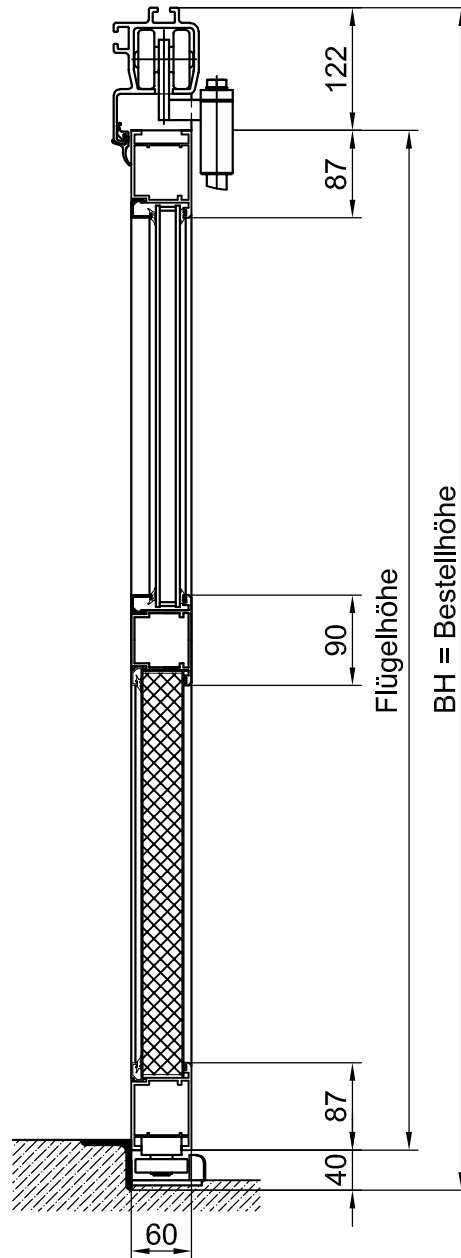

Vertikal und Horizontalschnitt

AL603F

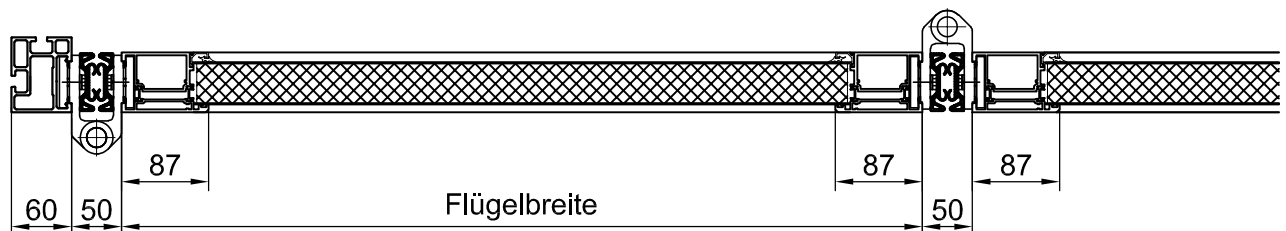
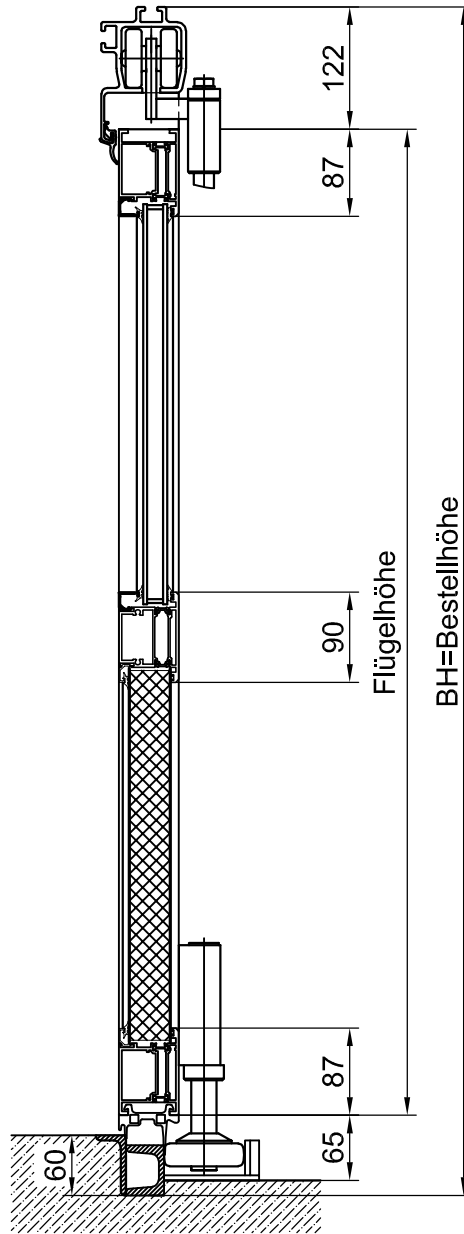

Vertikal und Horizontalschnitt

ST602F

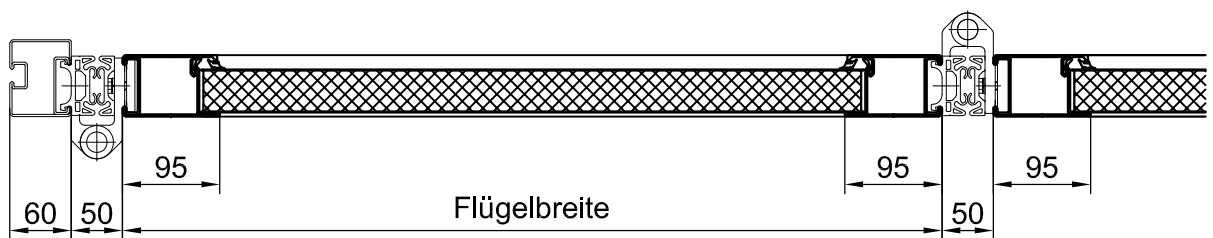
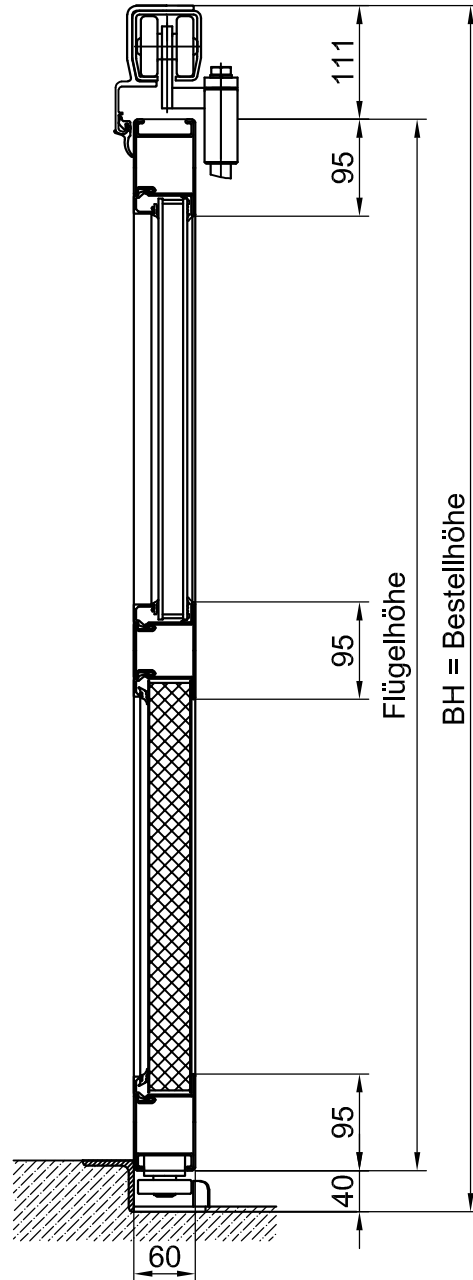

Kämpfer (Sprosse)

AL601F 2.0

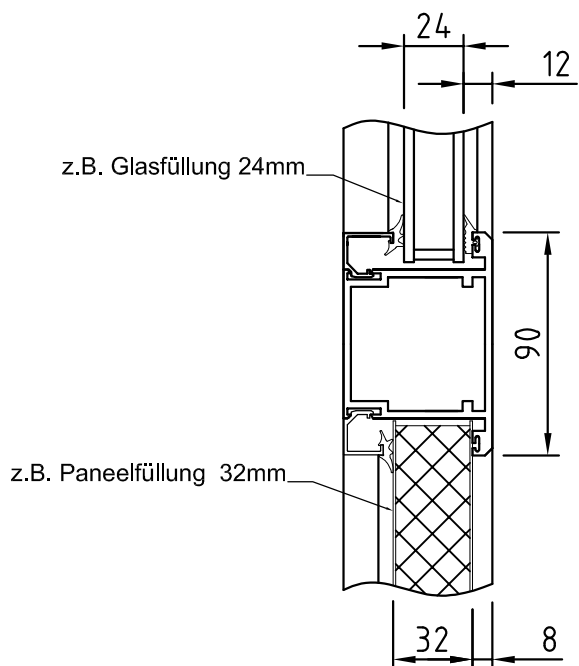

AL602F

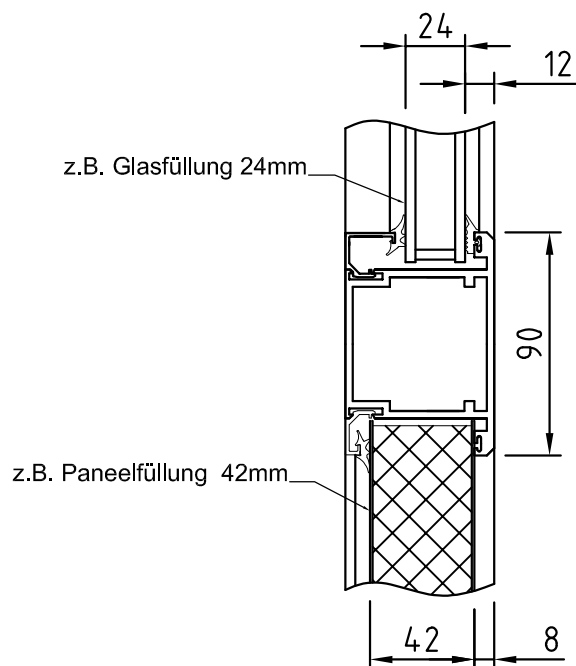

AL603F

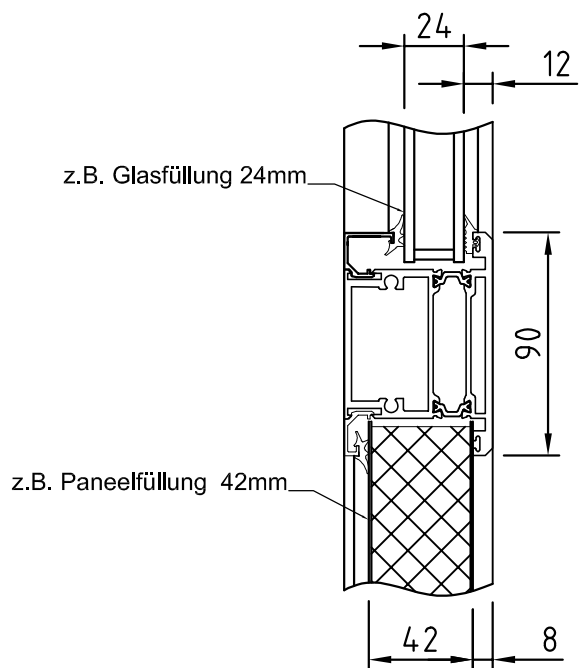

ST602F

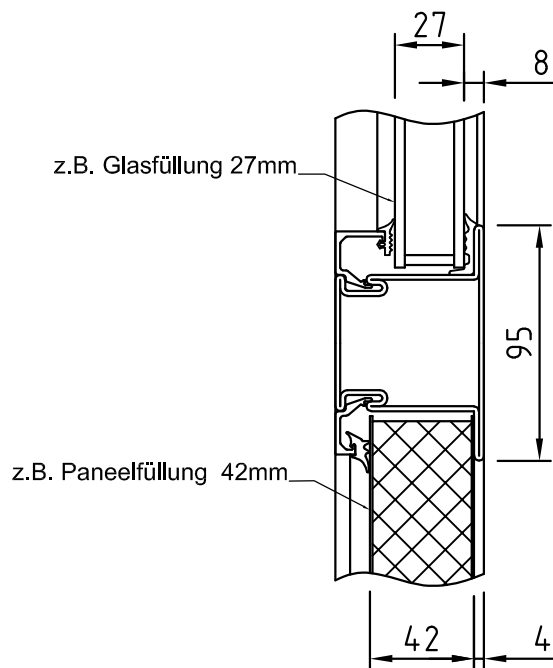

Rahmenverbreiterung

AL601F 2.0

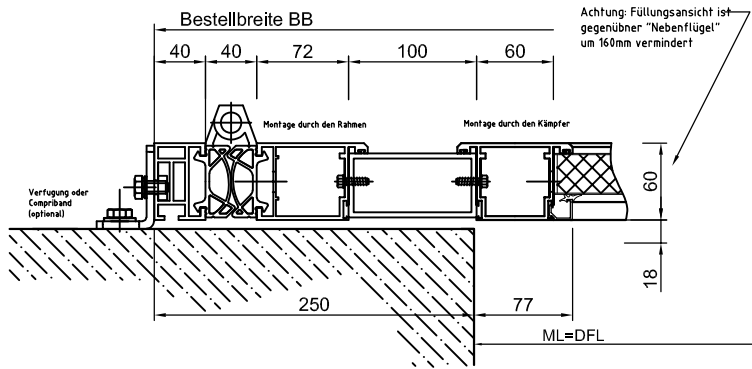

AL602F

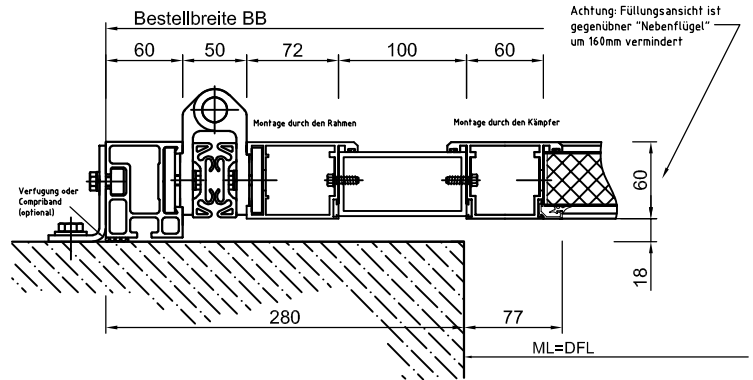

AL603F

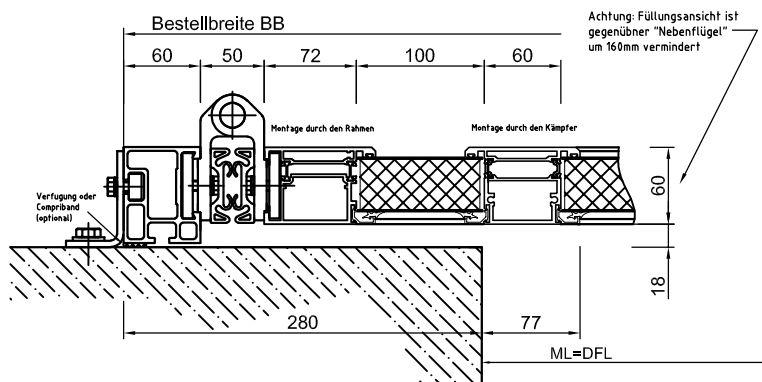

ST602F

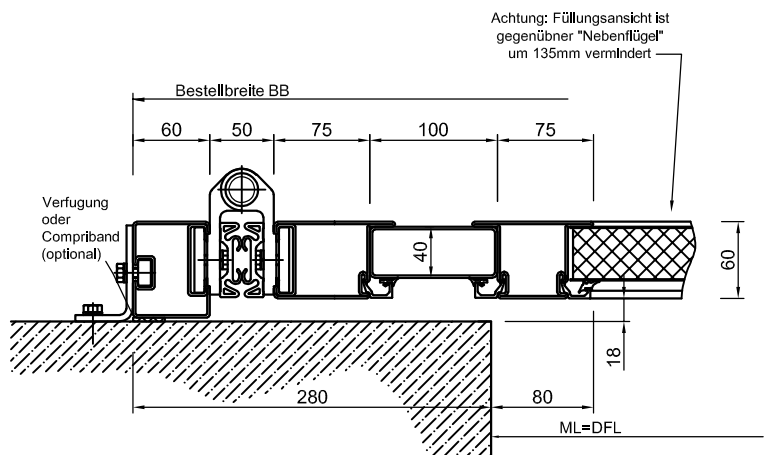

Gehflügel

AL601F 2.0

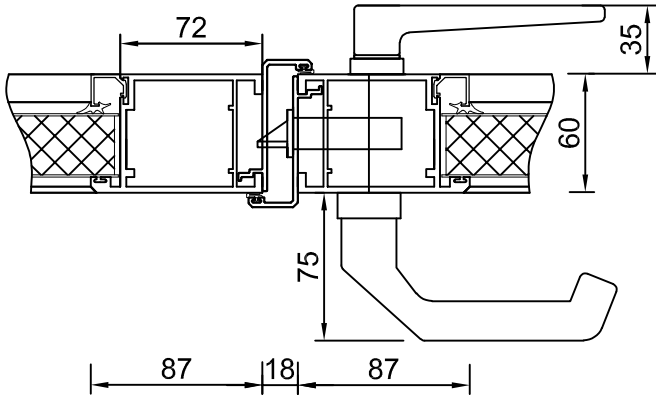

AL602F

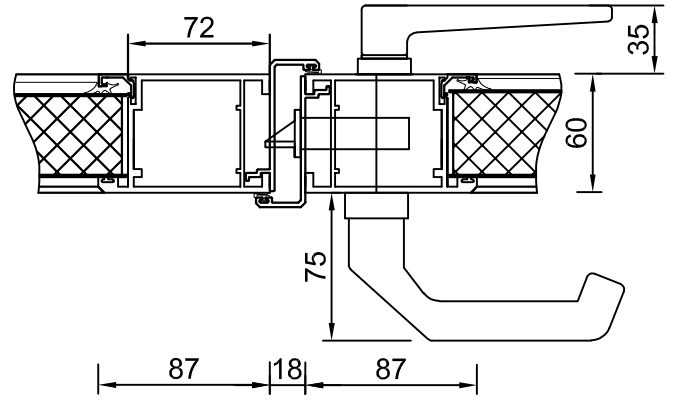

AL603F

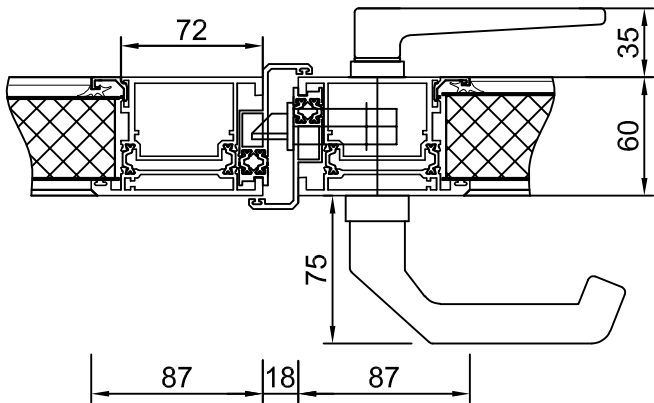

ST602F

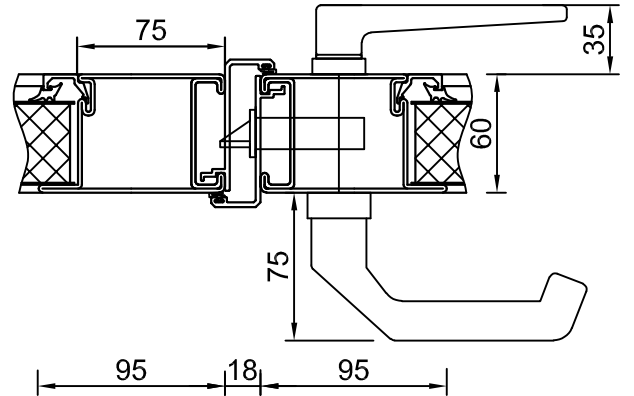

Schlupftüre Horizontalschnitt

nur nach Aussen öffnend möglich

AL601F 2.0

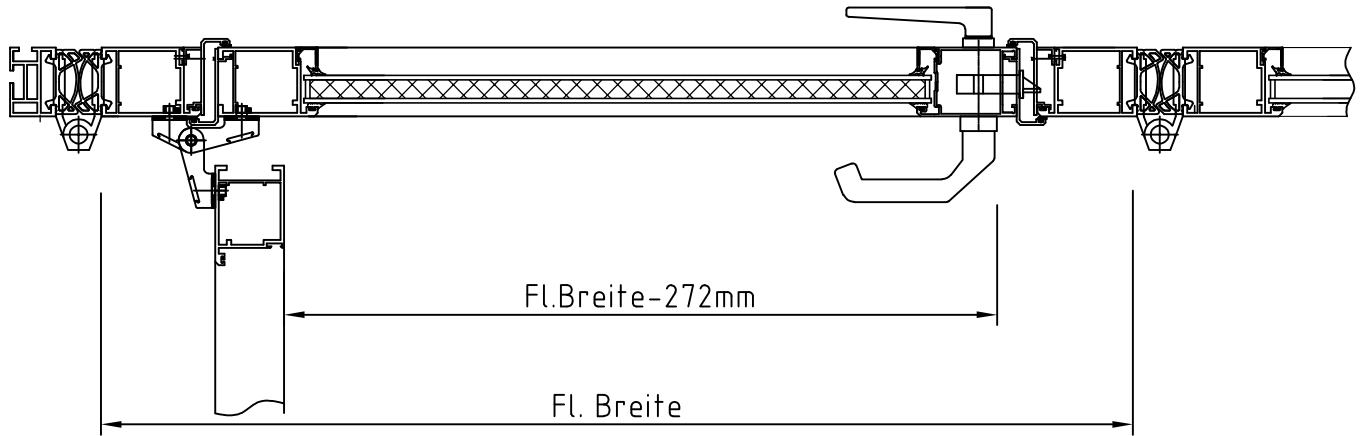

AL602F

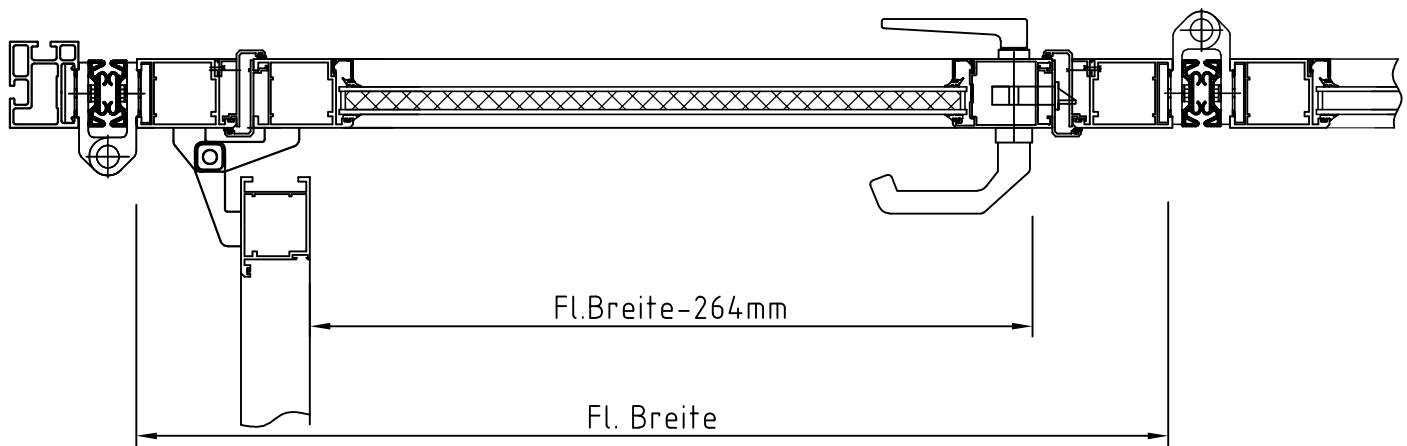

AL603F

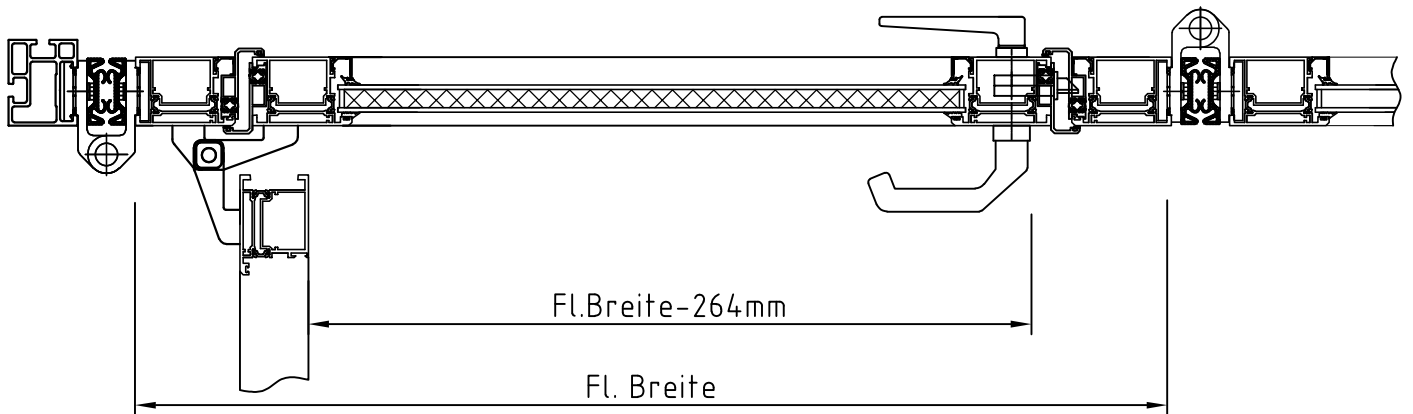

ST602F

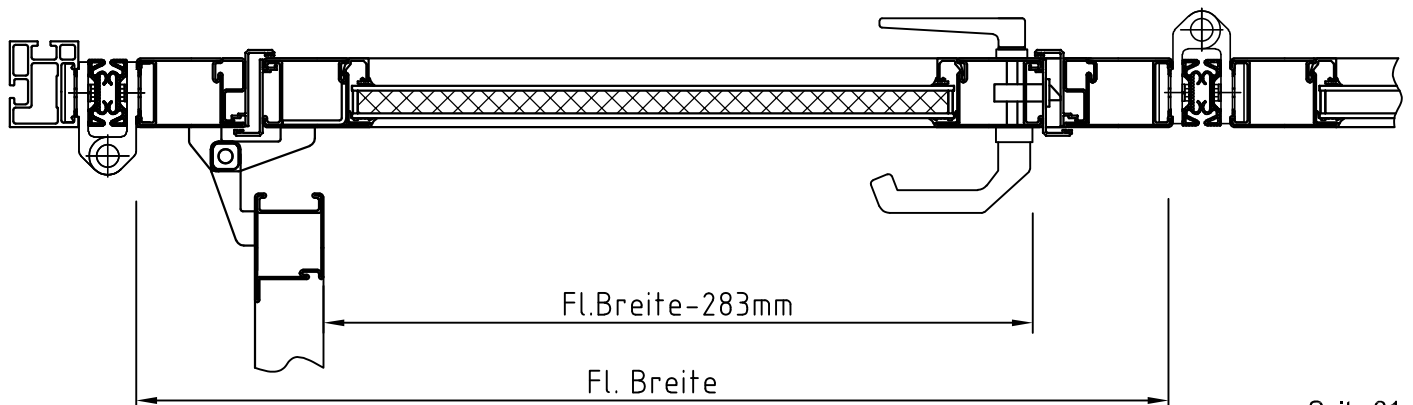

Schlupftüre Vertikalschnitt

nur nach Aussen öffnend möglich

AL601F 2.0

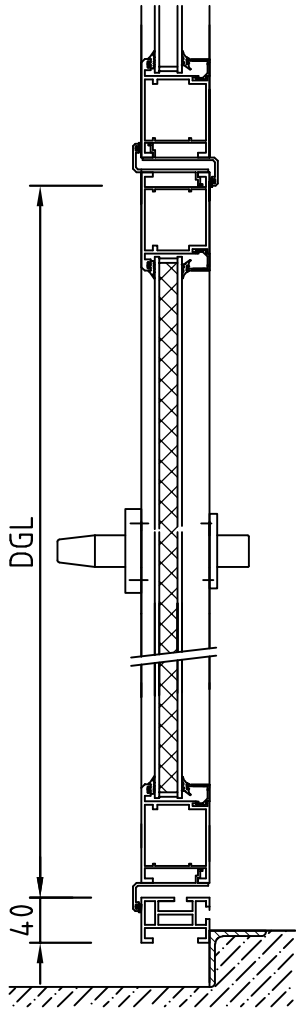

AL602F

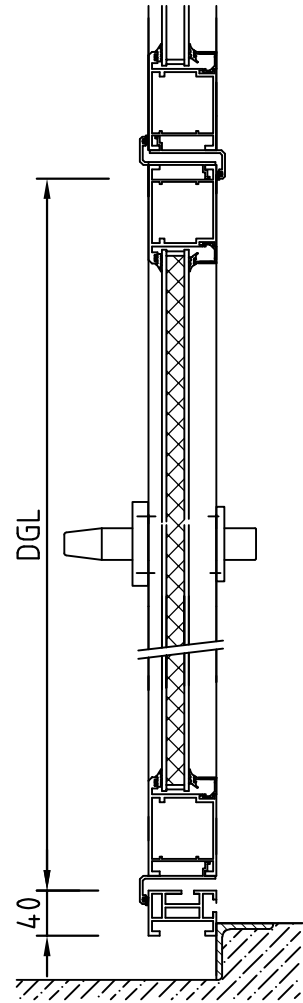

AL603F

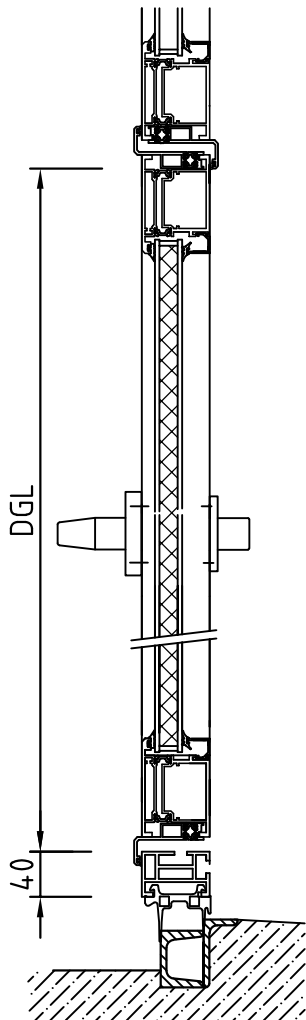

ST602F

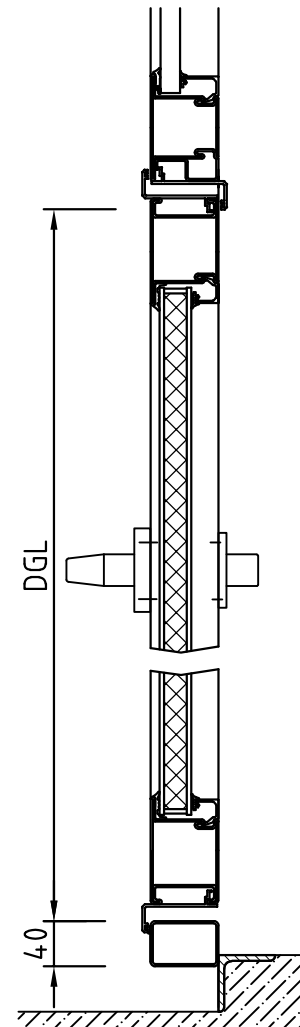

Schlupftüre Vertikalschnitt (Flachstahlschwelle)

nur nach Aussen öffnend möglich

AL601F 2.0

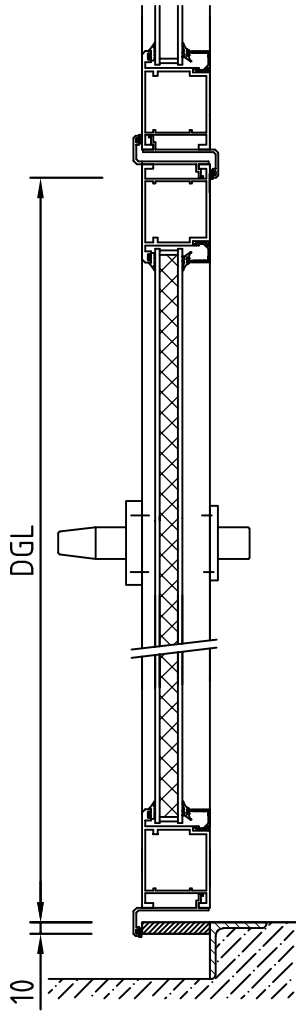

AL602F

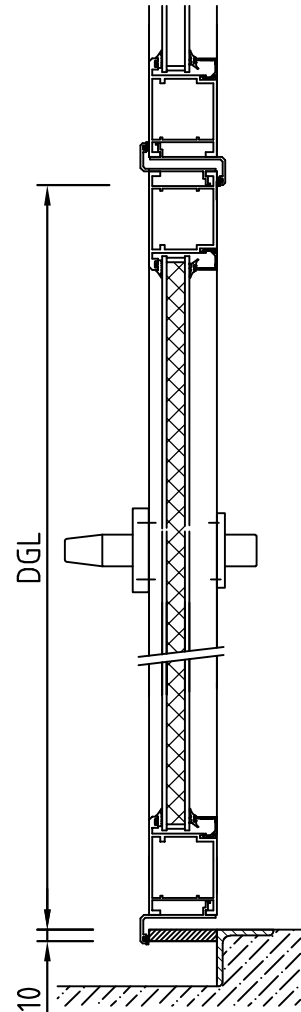

AL603F

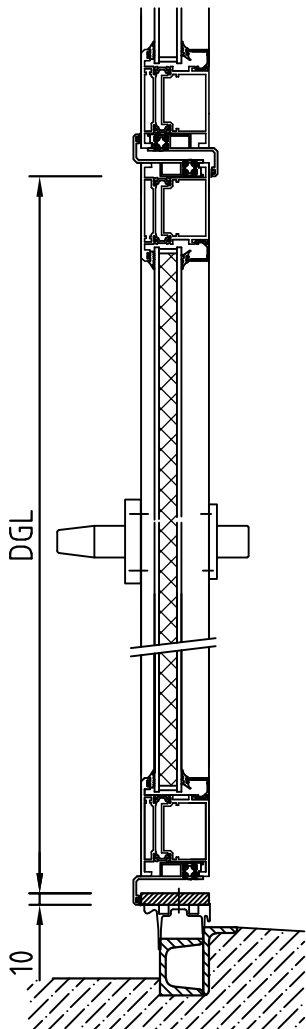

ST602F

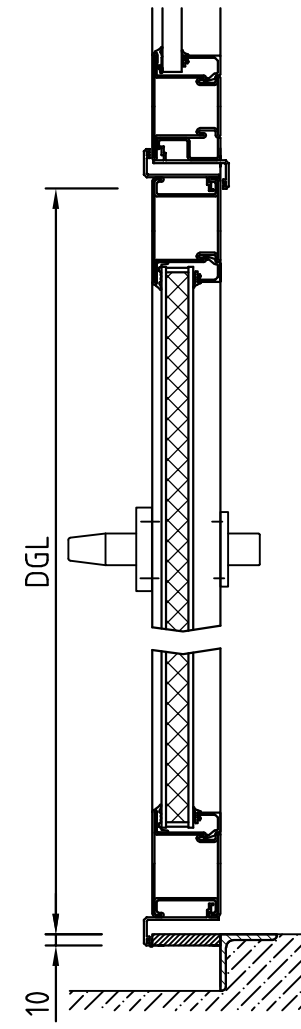

Schlupftüre Vertikalschnitt (Formrohrschwelle)

nur nach Aussen öffnend möglich und nur bei Niedrigschwelle mit Dichtbürste

AL601F 2.0

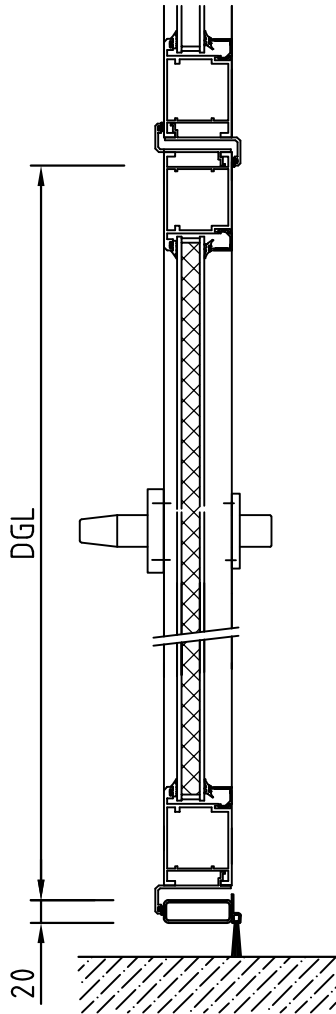

AL602F

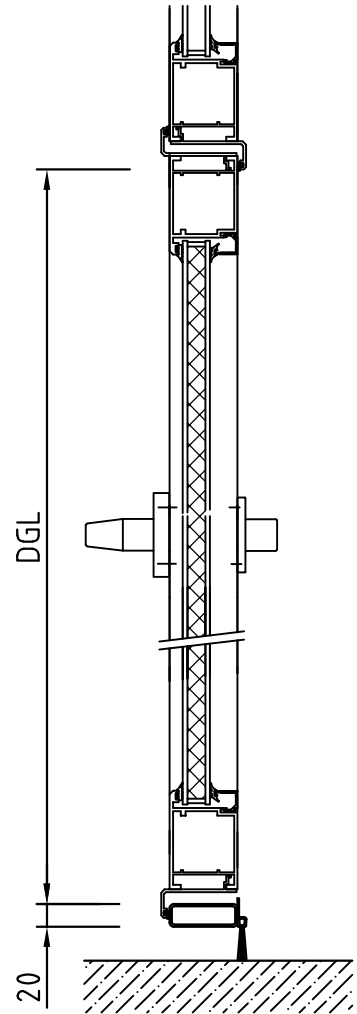

AL603F

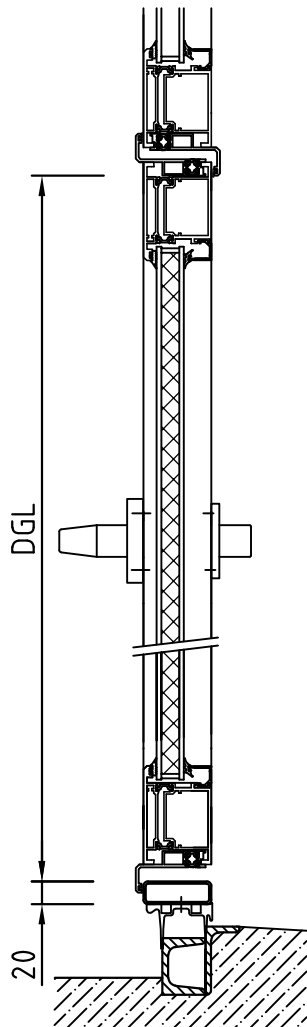

ST602F

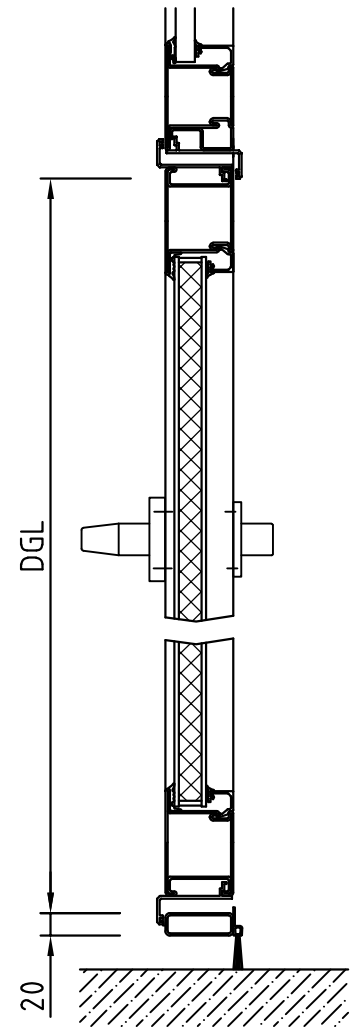

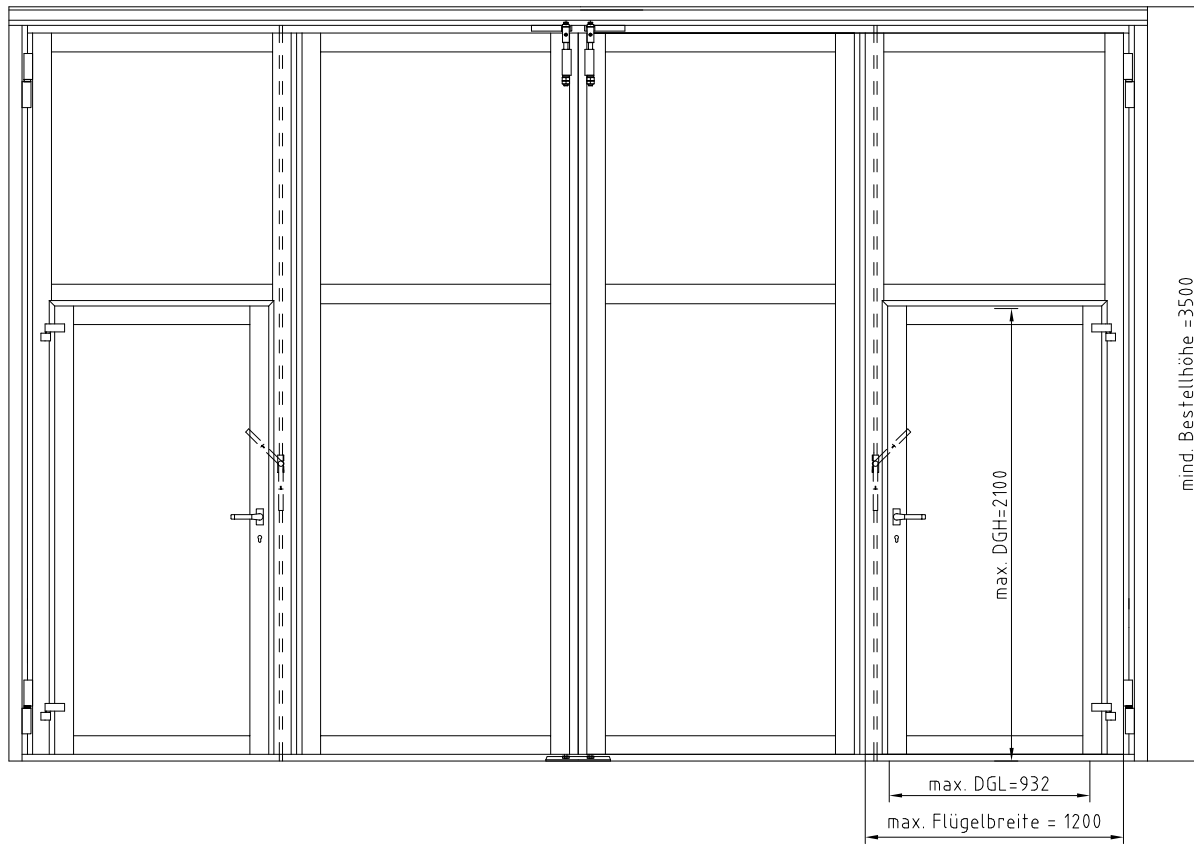

Vertikalschnitt

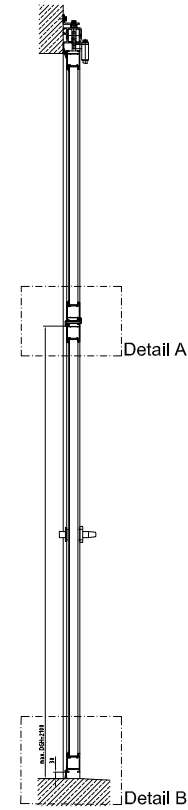

Detail A

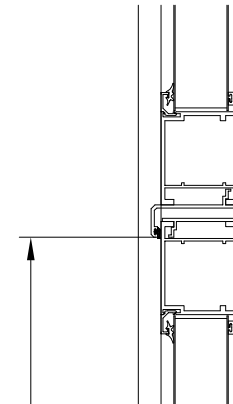

Detail B

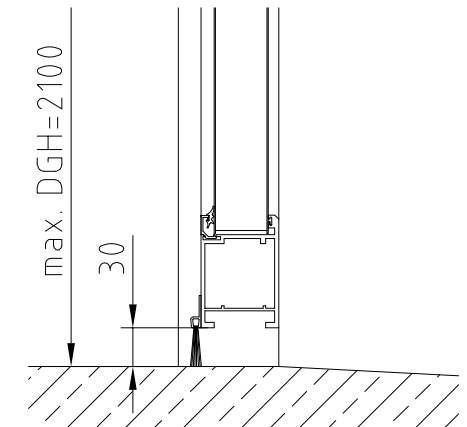

Horizontalschnitt

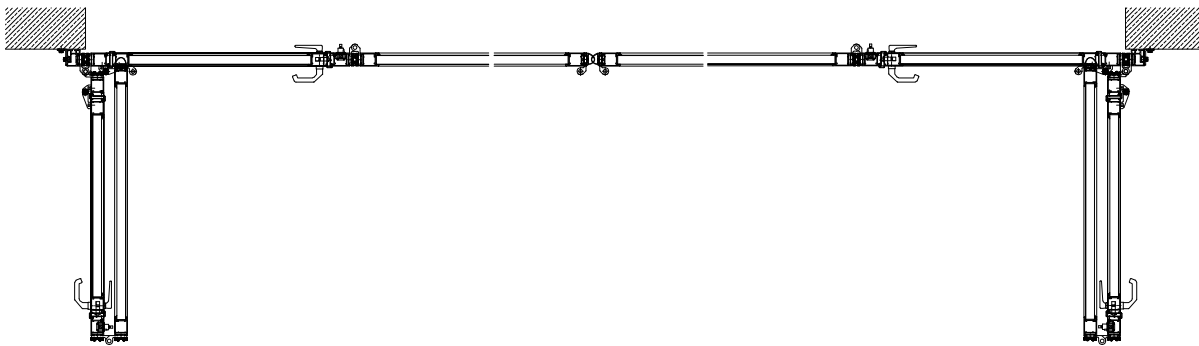

Systemzeichnung Schwellenlose Schlupftür

Schlupftüre Vertikalschnitt (ohne Schwelle)

Bänder nur Stockseitig möglich, min.BH 4000mm

AL601F 2.0

AL602F

nicht möglich

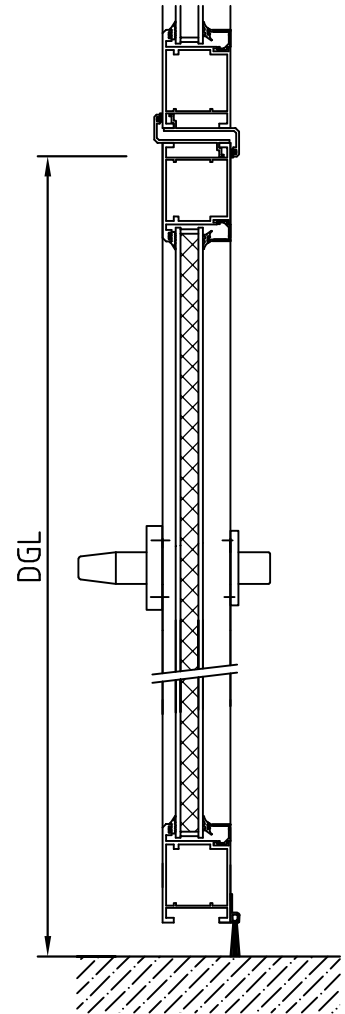

AL603F

ST602F

nicht möglich

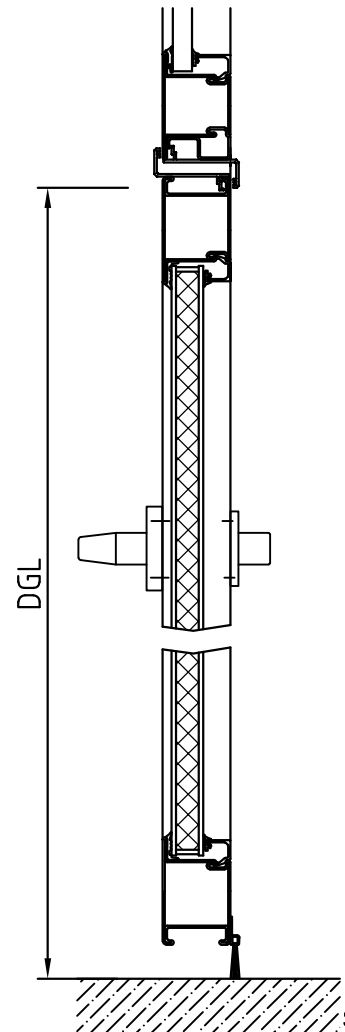

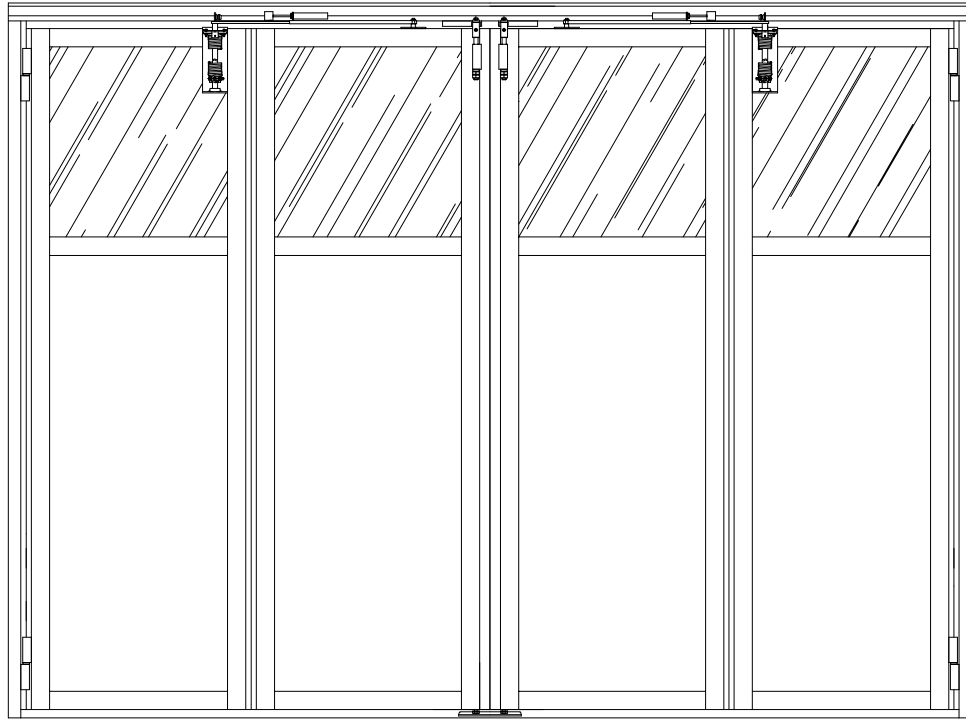

Vertikalschnitt

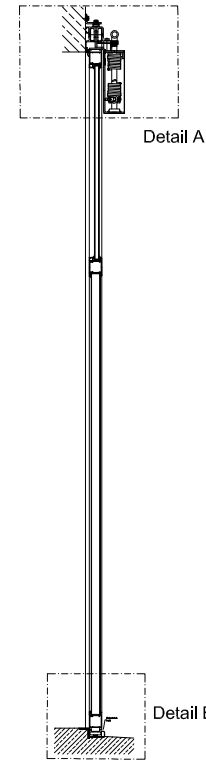

Detail A

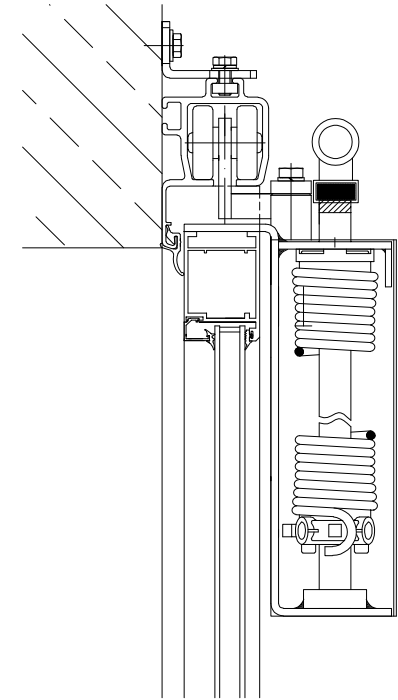

Horizontalschnitt

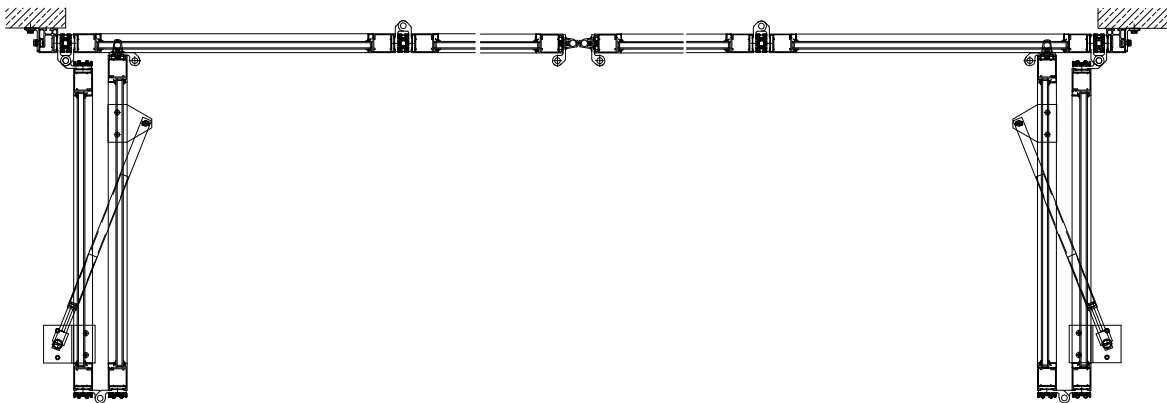

Detail B

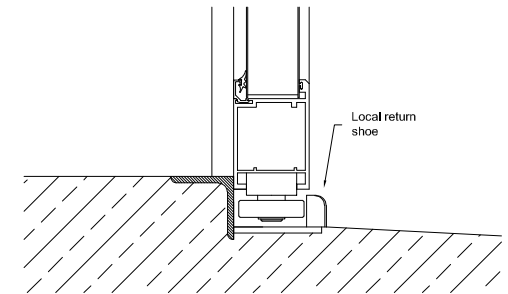

Systemzeichnung Öffnungsautomatik

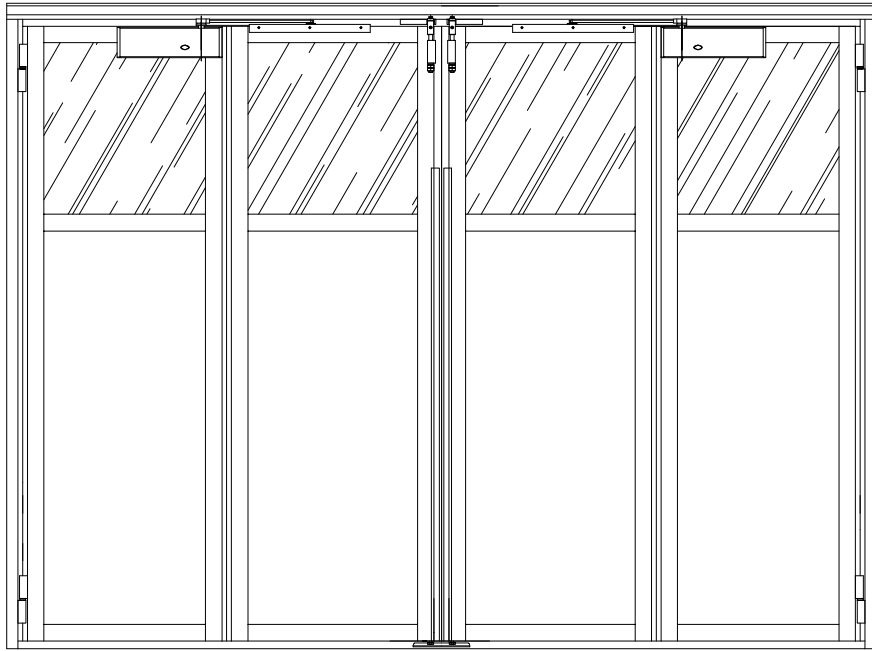

Vertikalschnitt

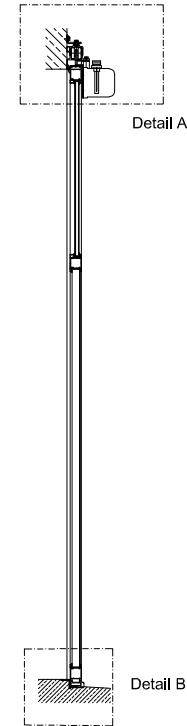

Detail A

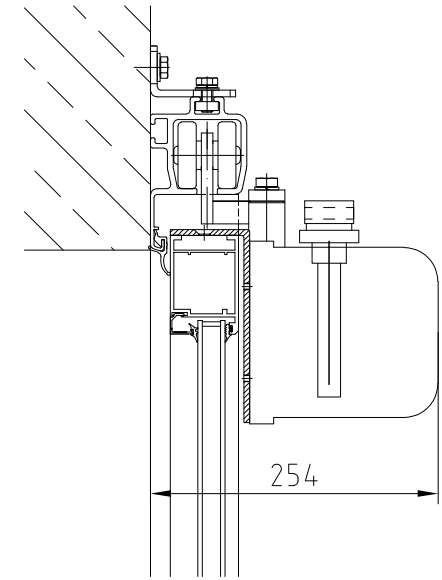

Horizontalschnitt

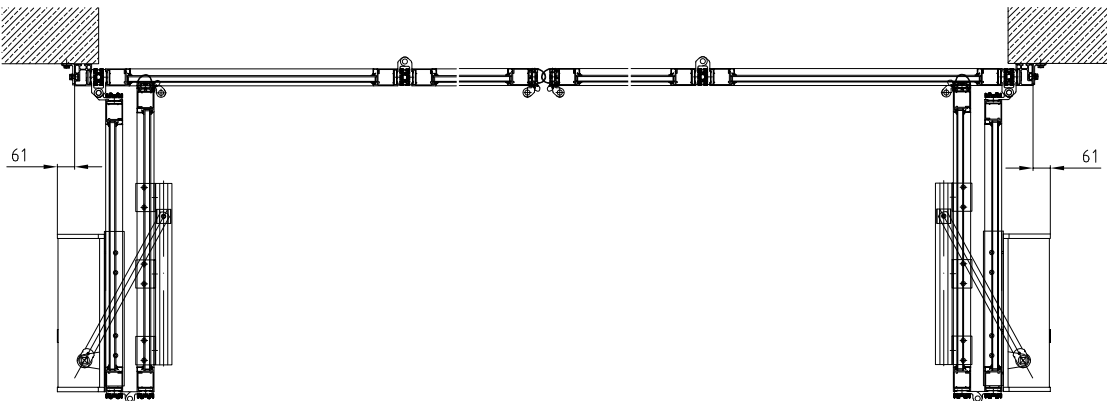

Detail B

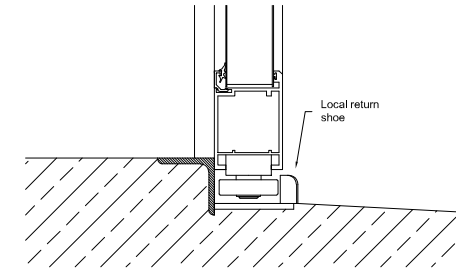

Systemzeichnung Falttorantrieb BASIC

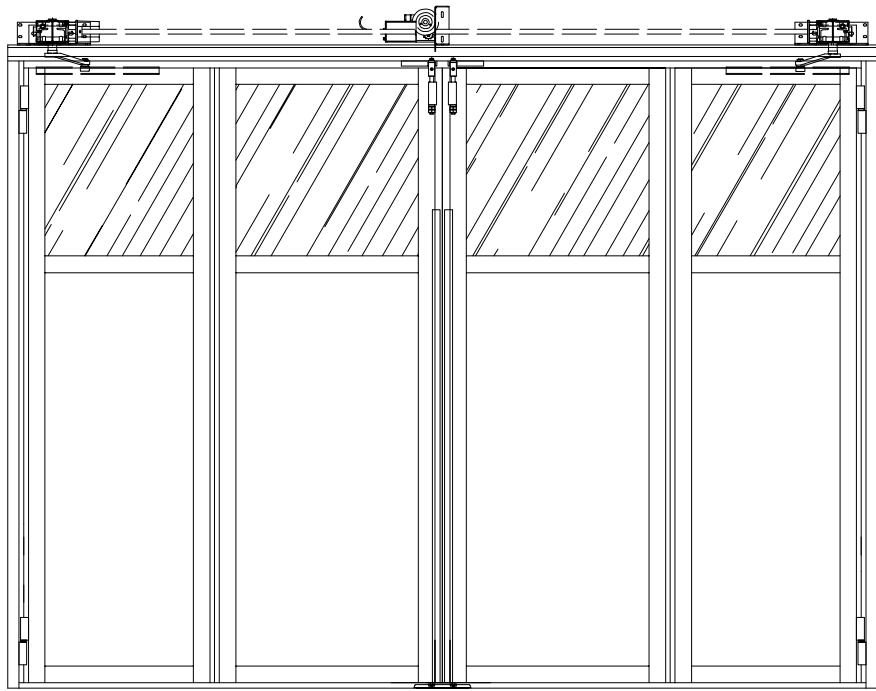

Horizontalschnitt

Vertikalschnitt

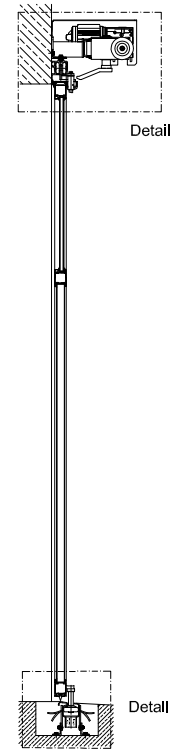

Detail A

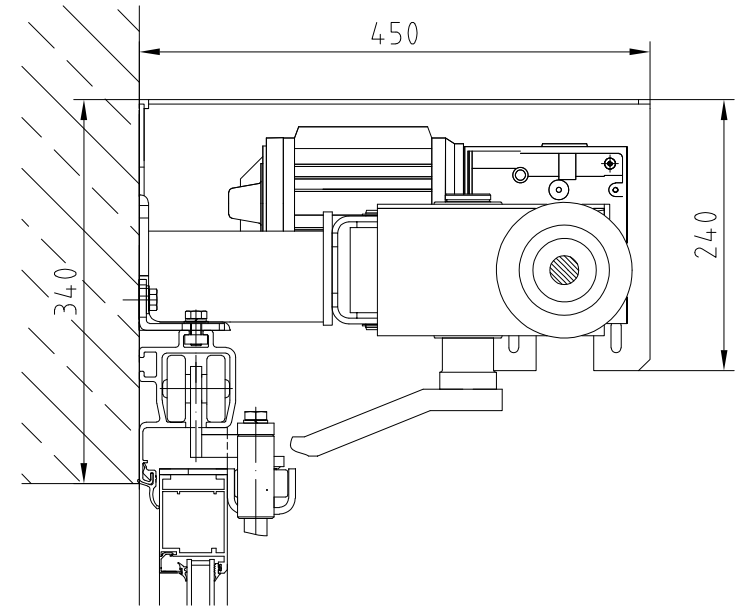

Detail B

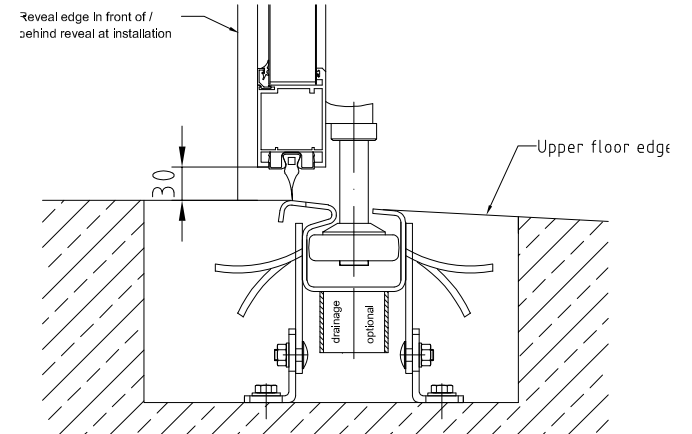

Systemzeichnung Faltdorantrieb POWER