

Schiebetore
Alu AL602S
Alu therm. getrennt AL603S
Stahl ST602S
BR600

T E C H N I K
Version 2018/04

SCHNEIDER Torsysteme Ges.m.b.H.
Kalzitstrasse 1
A-4611 Buchkirchen
Tel. +43 7243/545 88-0
Fax. +43 7243/545 88-6
Web. www.schneider.co.at



Gültig ab 01.04.2018

Alle bisherigen Unterlagen verlieren ihre Gültigkeit. Technische Änderungen, Druck- und Satzfehler, drucktechnische Farbabweichungen vorbehalten. Darstellungen sind nur beispielhaft.

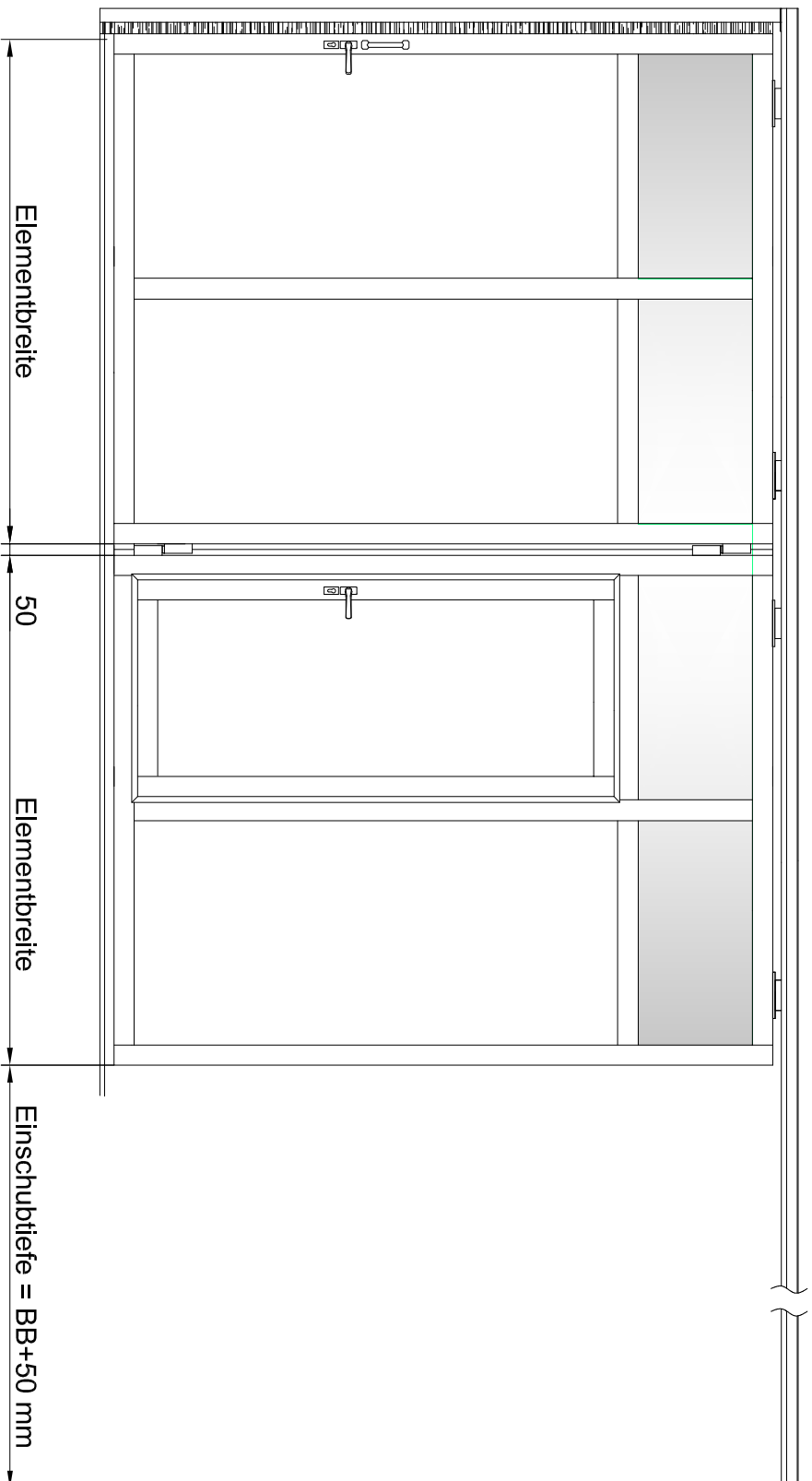

Vertikalschnitt

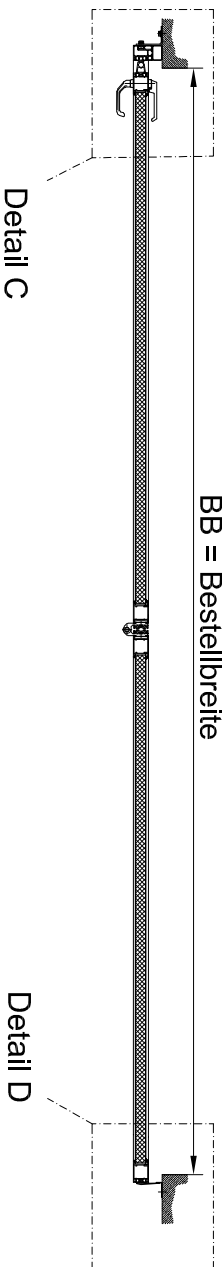
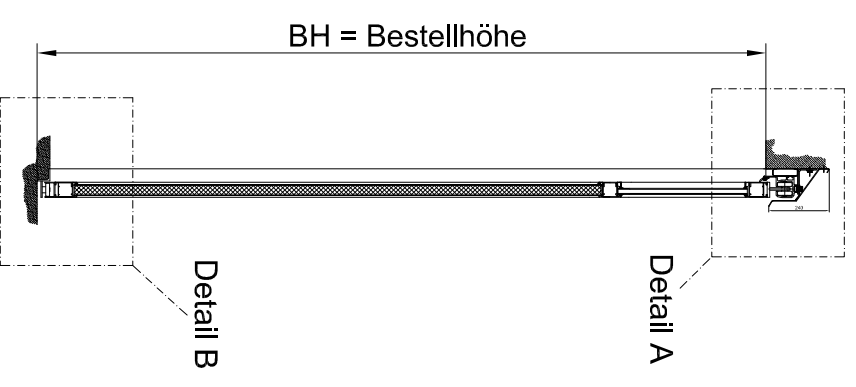

Horizontalschnitt
BB = Bestellbreite

Größenbereich Schiebeter			
Type	AL602S	AL603S	ST602S
Material	Aluminium	Aluminium thermisch getrennt	Stahl
max. Torgrösse BB x BH	13000 x 5600 mm	13000 x 5600 mm	13000 x 5600 mm
max. Elementbreite	2900 mm	2900 mm	2900 mm

Systemzeichnung Schiebeter AL602S, AL603S, ST602S

Montageposition Sturz vor/hinter der Leibung - Detail A

AL602S

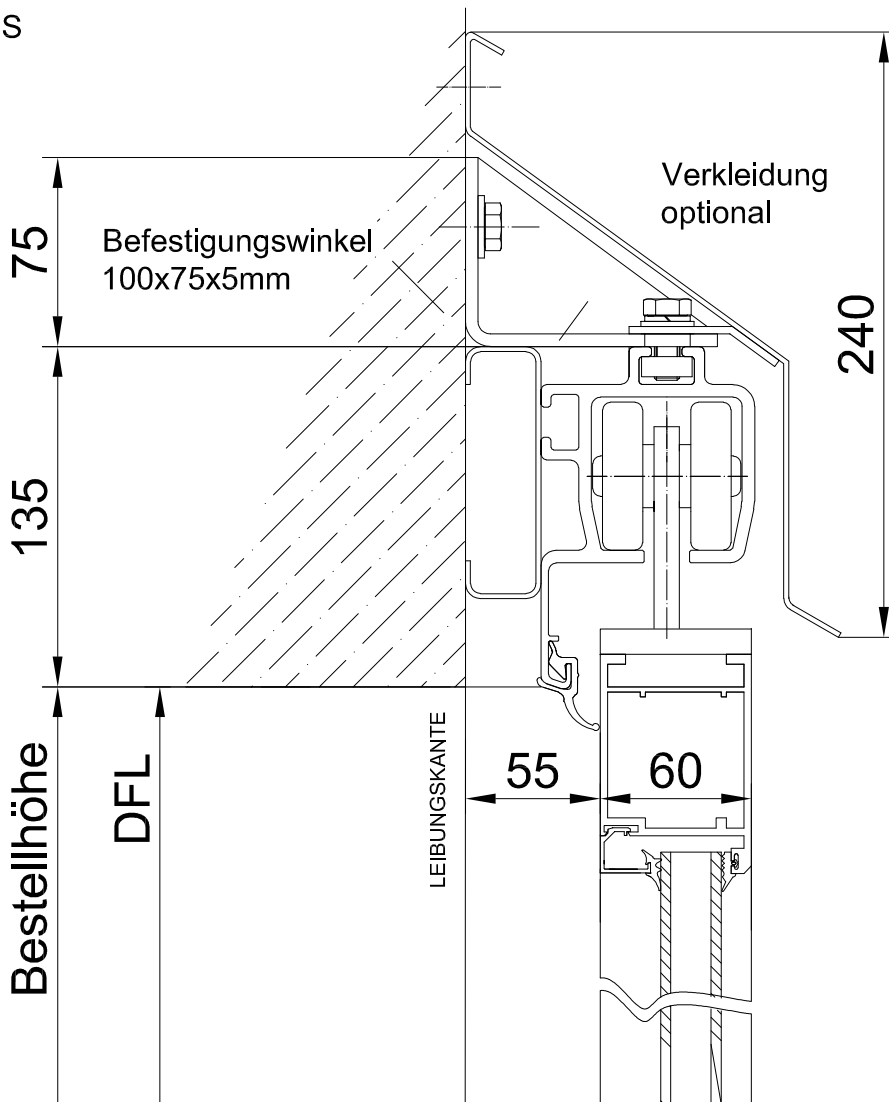

AL603S

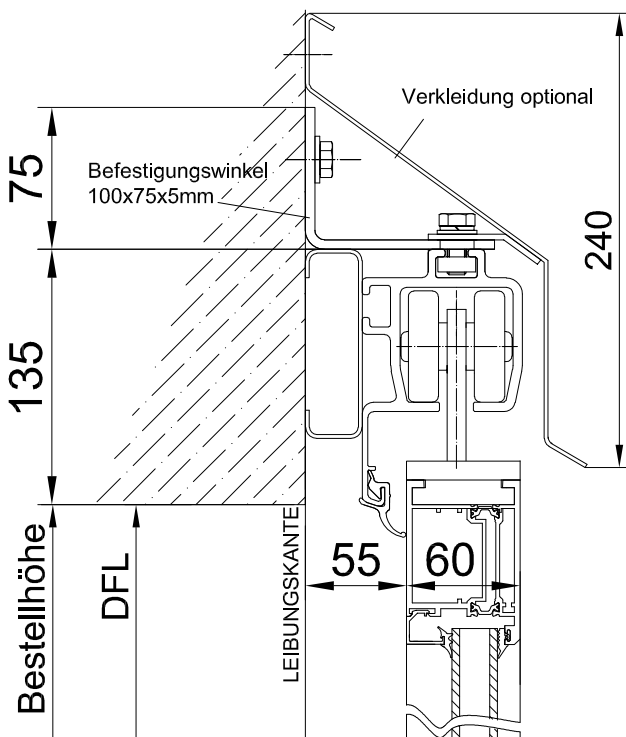

ST602S

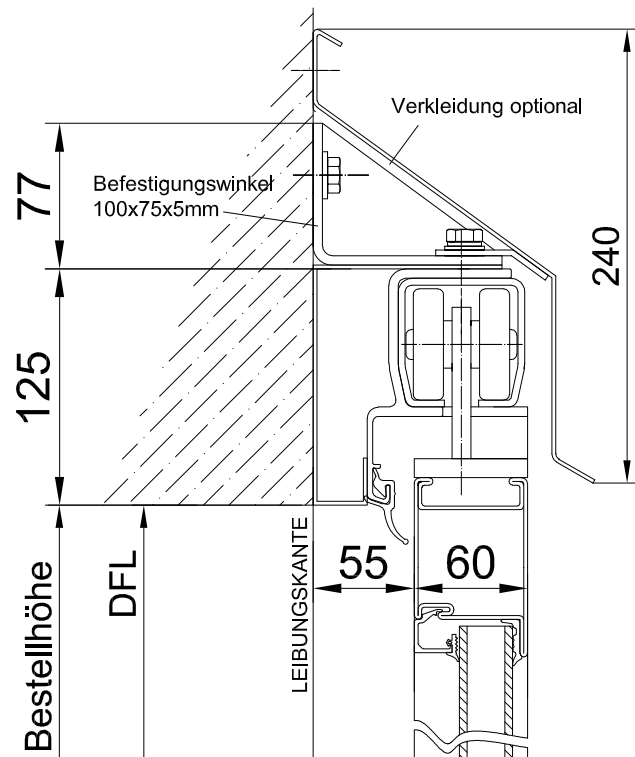

Montageposition Sturz in der Leibung - Detail A

AL602S

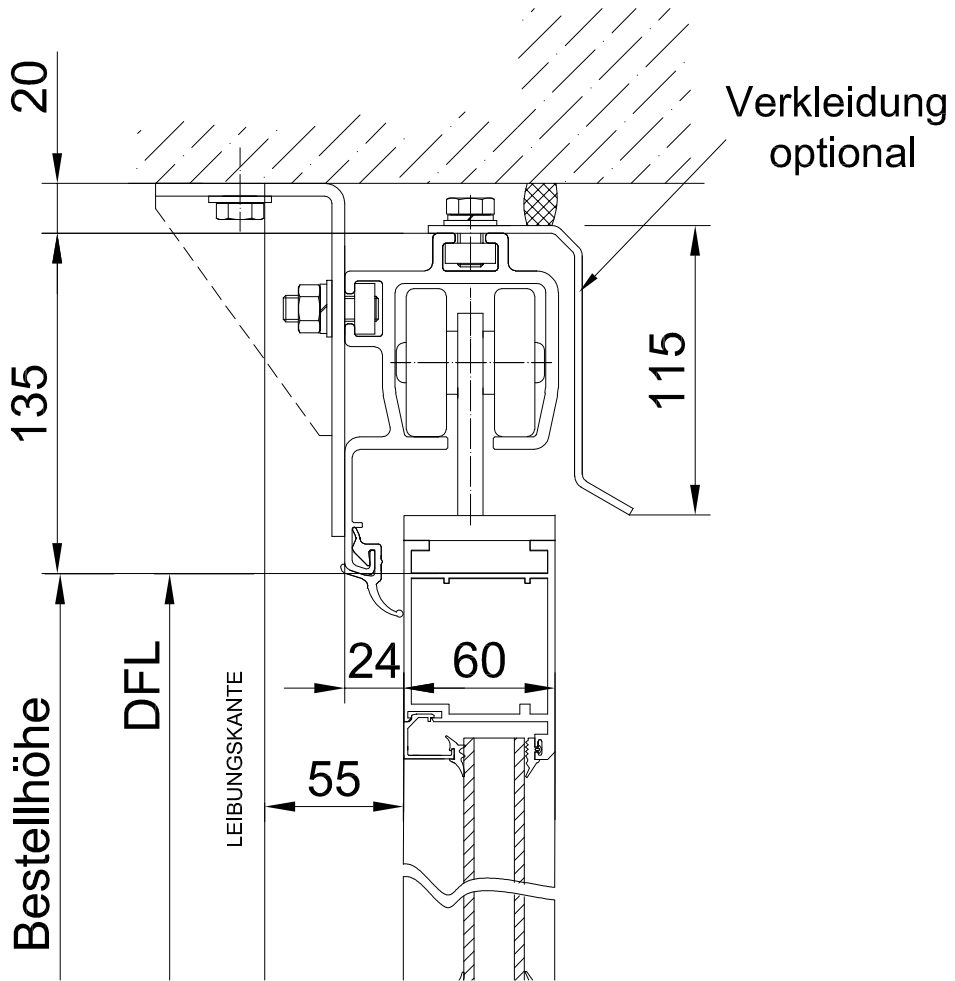

AL603S

ST602S

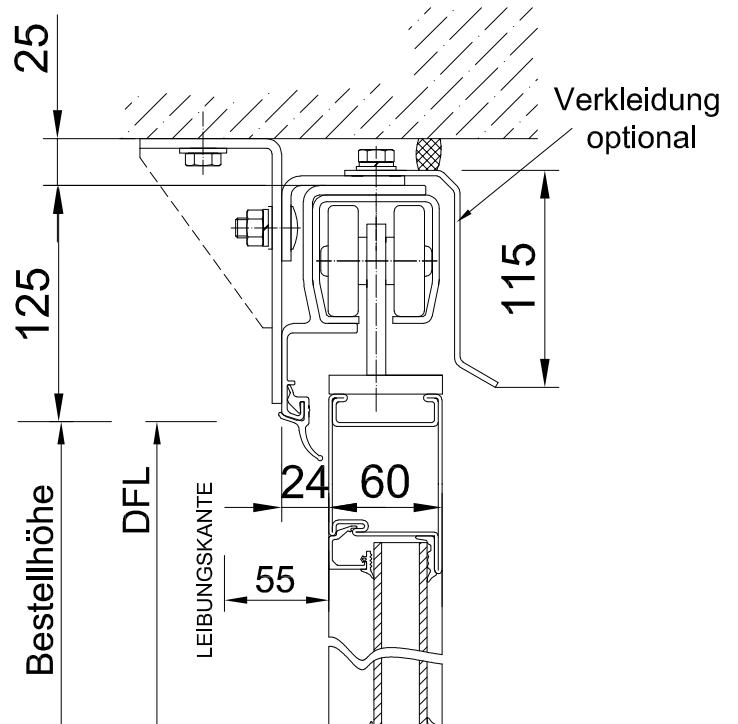
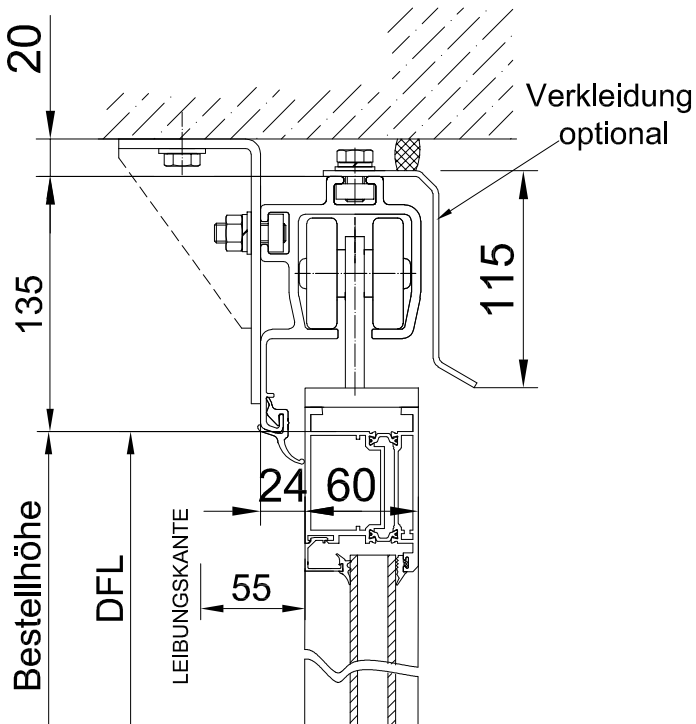

Bodenabschluss

Schwelle Anschlagwinkel L50 - Detail B

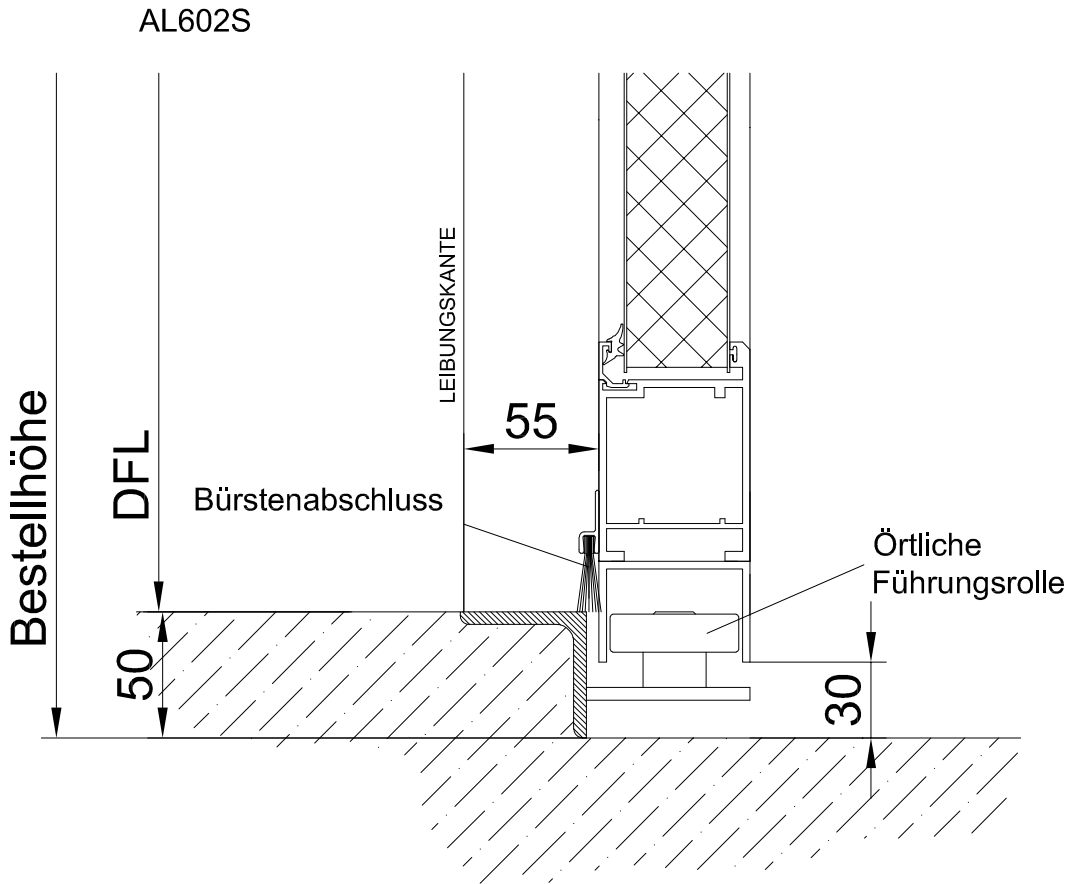

AL603S

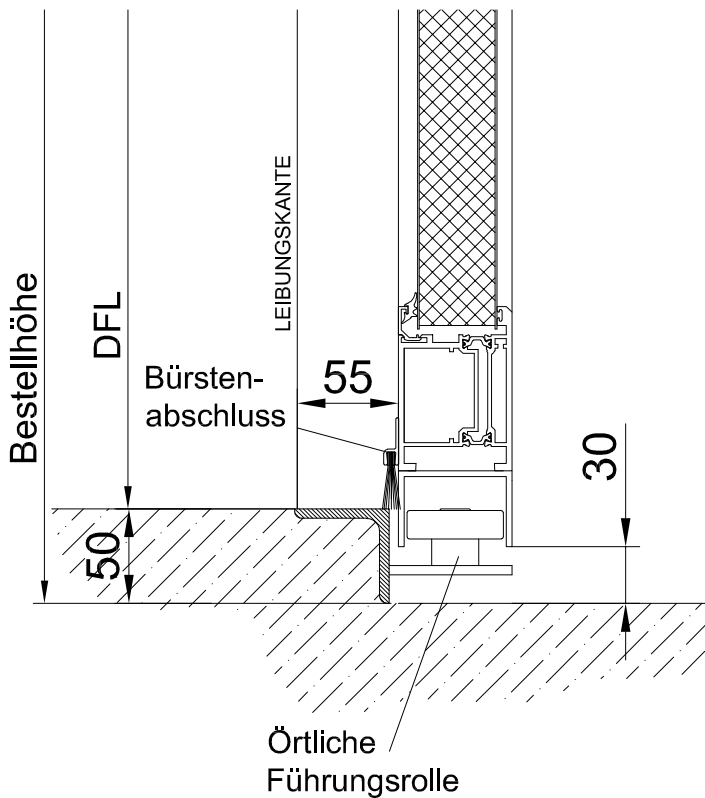

ST602S

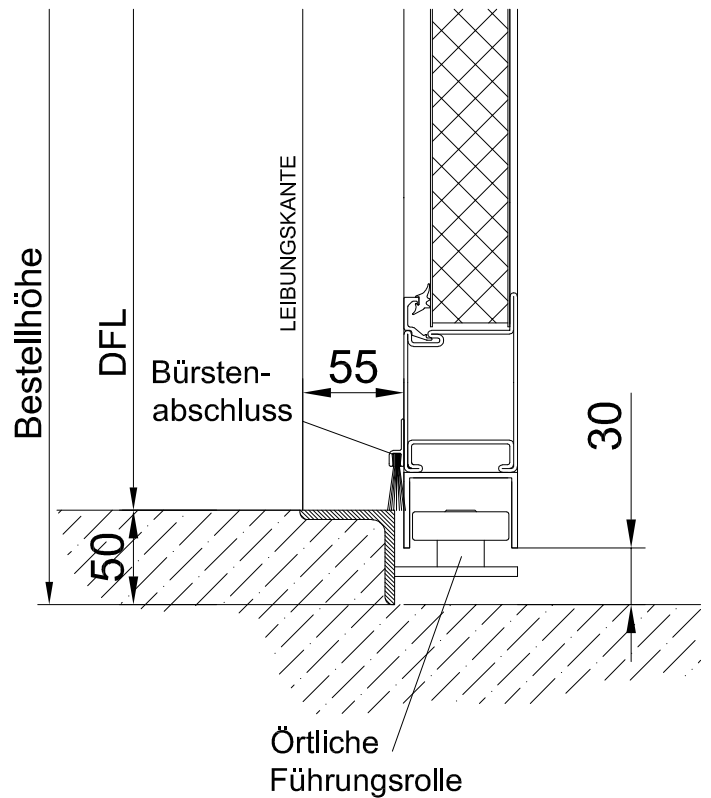

Bodenabschluss

Schwelle Anschlagprofil U50 - Detail B

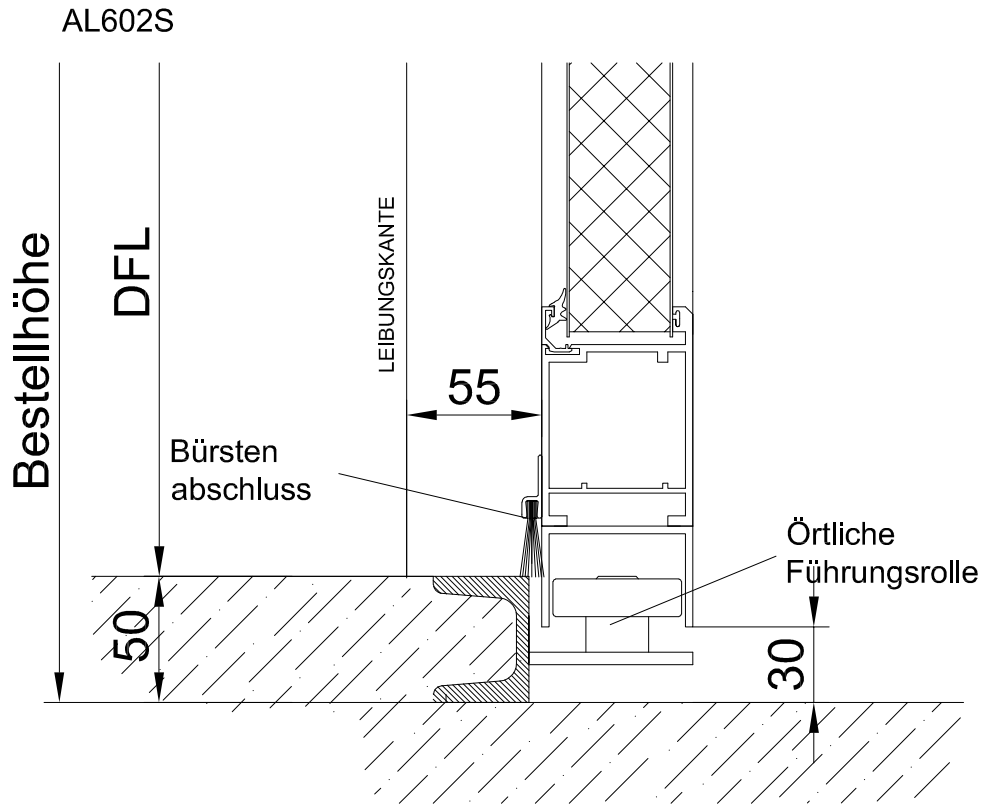

AL603S

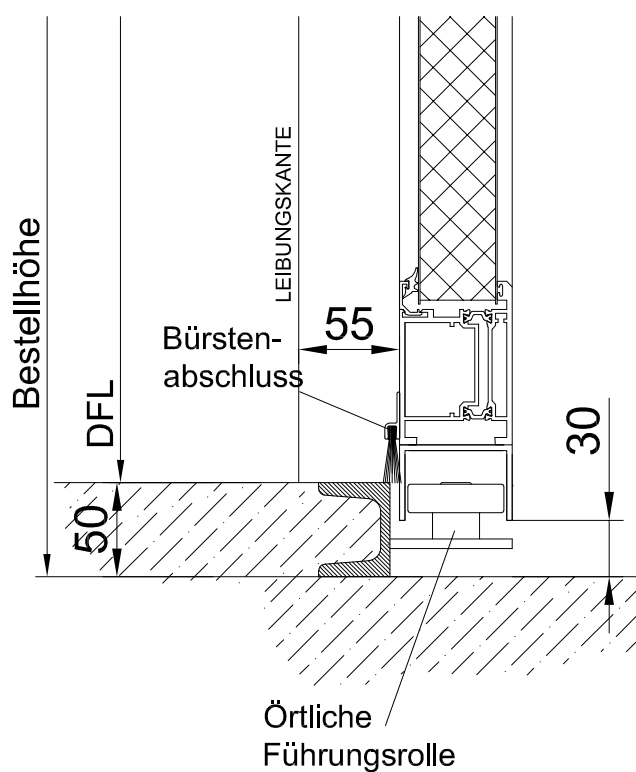

ST602S

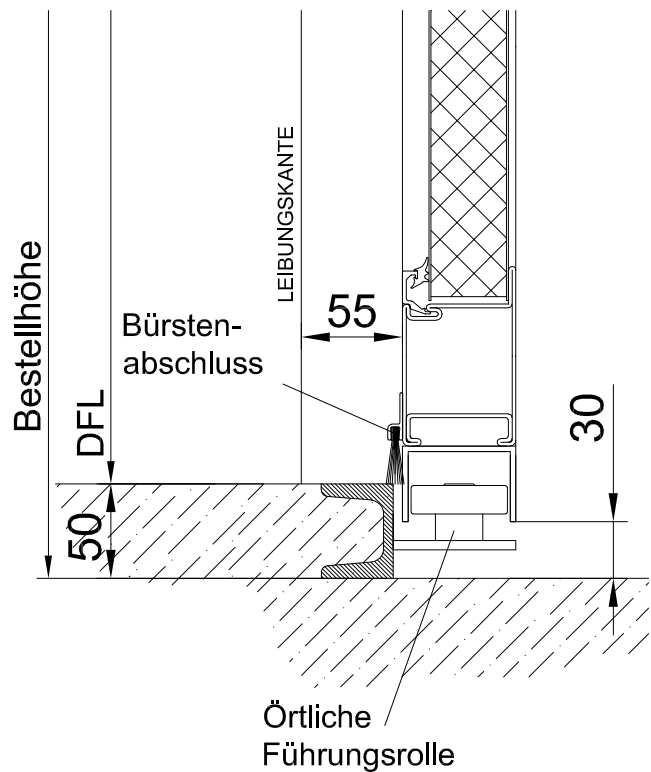

Bodenabschluss

Bodenführung BF - Detail B

AL602S

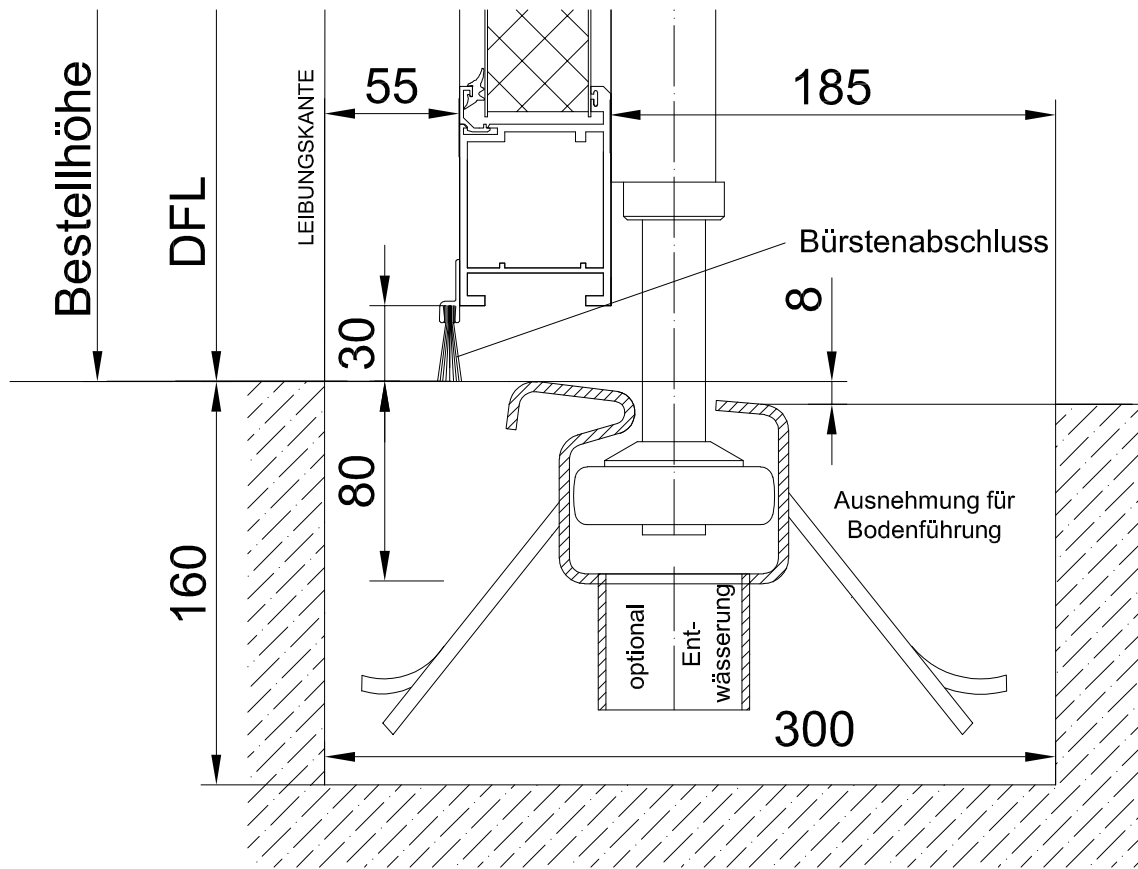

AL603S

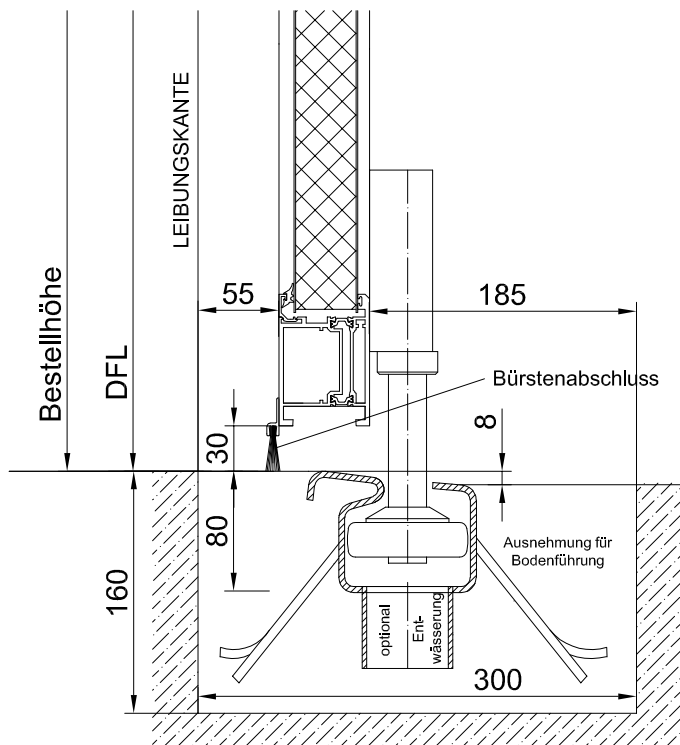

ST602S

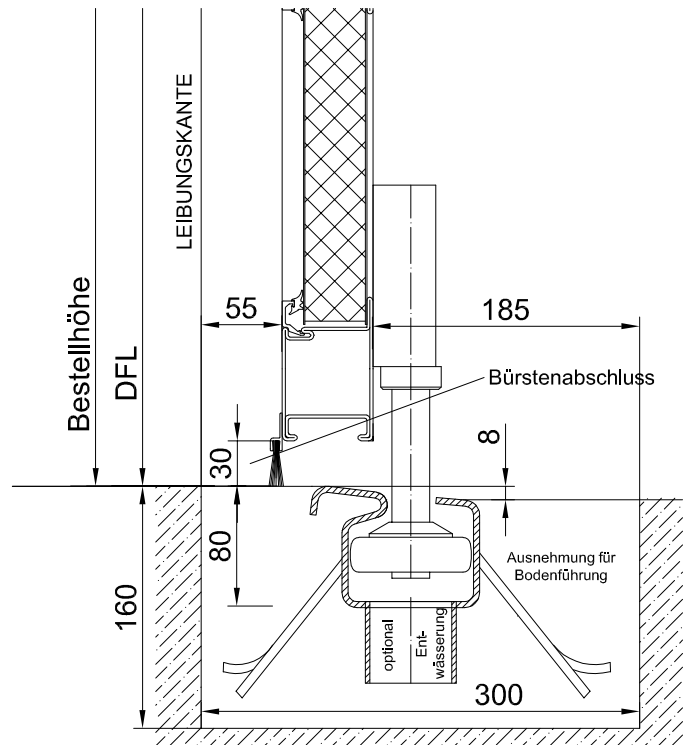

Bodenabschluss

Bodenführung beheizt BF bhz. - Detail B

AL602S

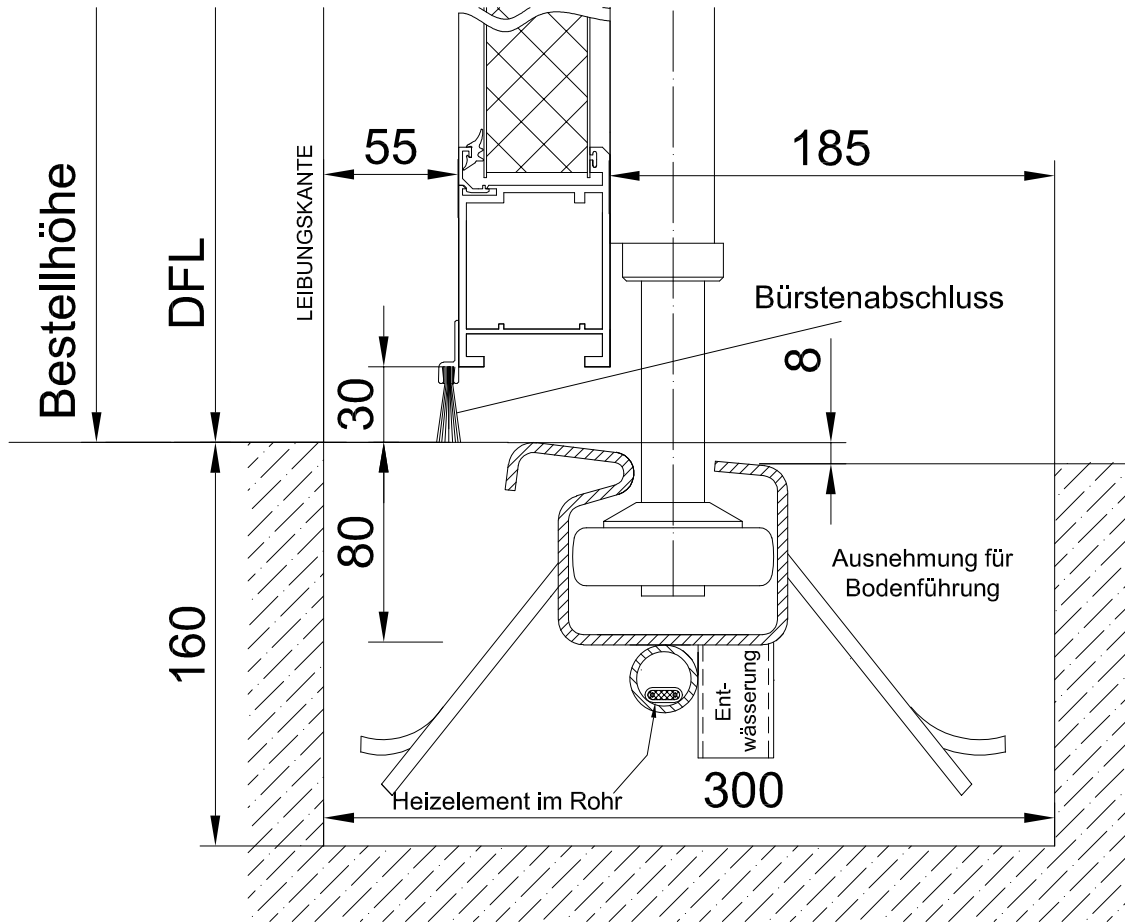

AL603S

ST602S

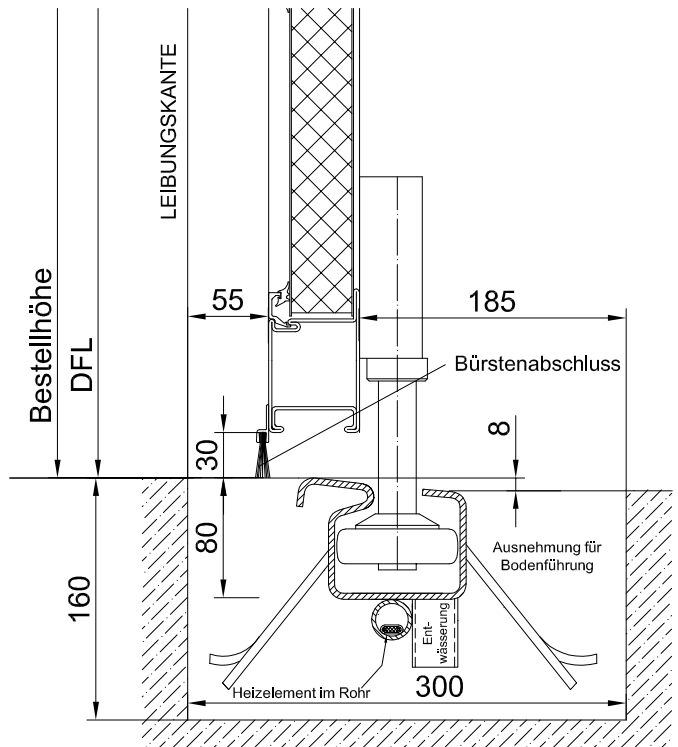
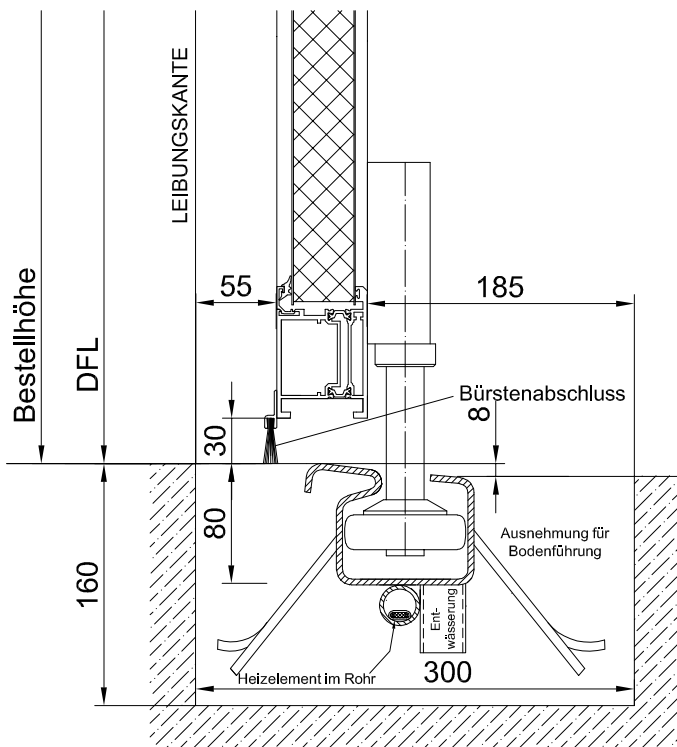

Bodenführung BF-light NIRO

AL602S

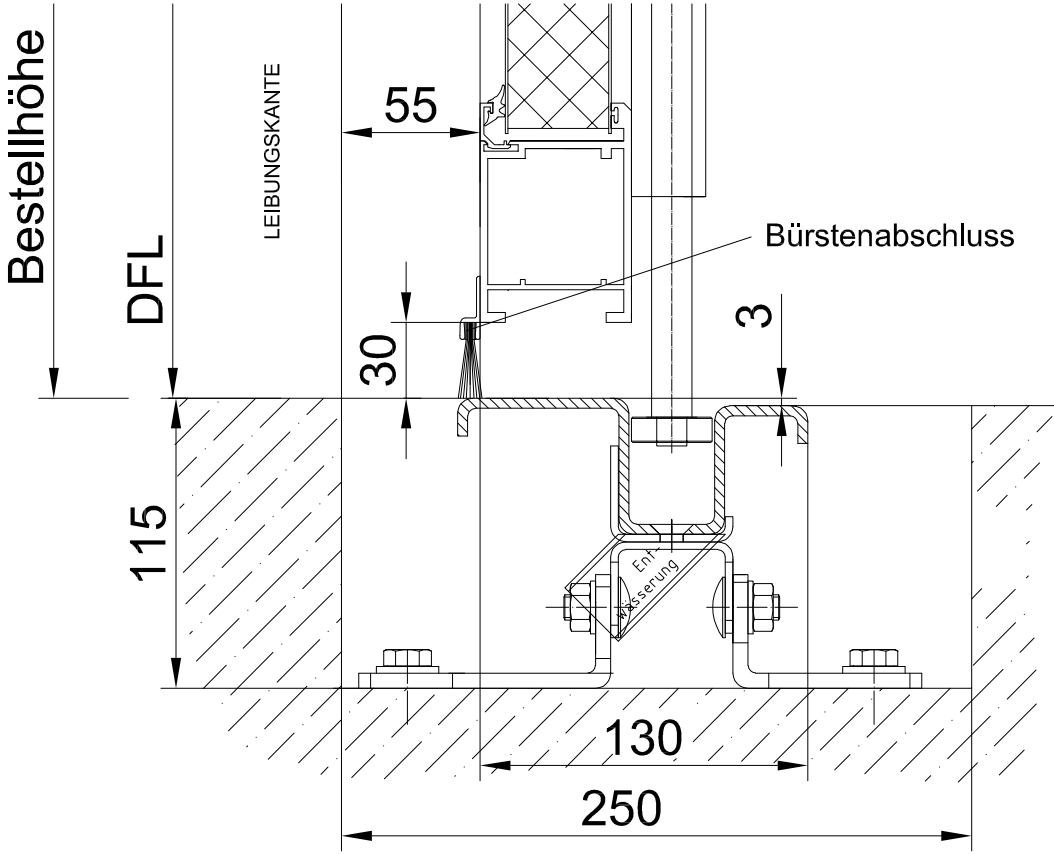

AL603S

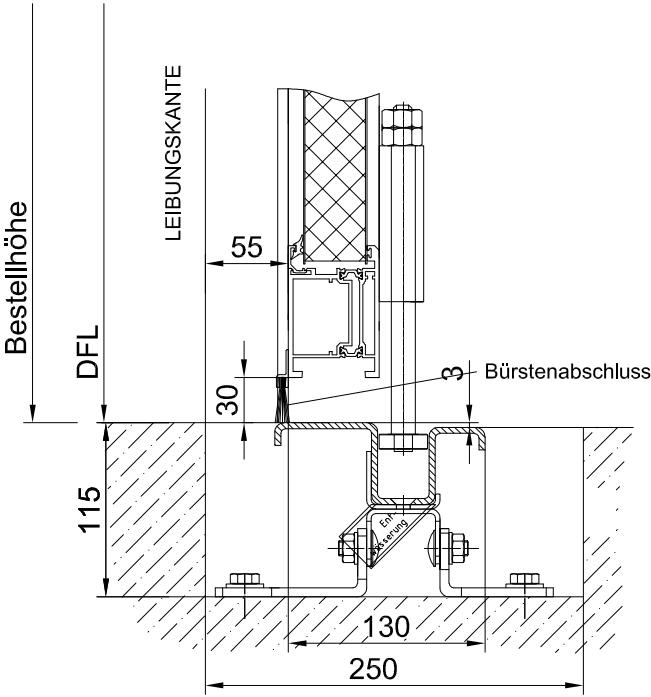

ST602S

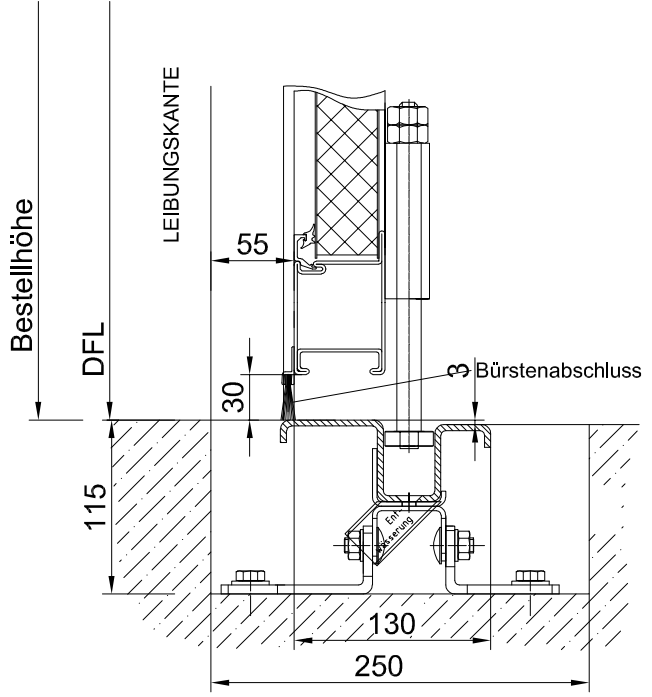

Bodenabschluss

Bodenführung beheizt BF-light NIRO bhz

AL602S

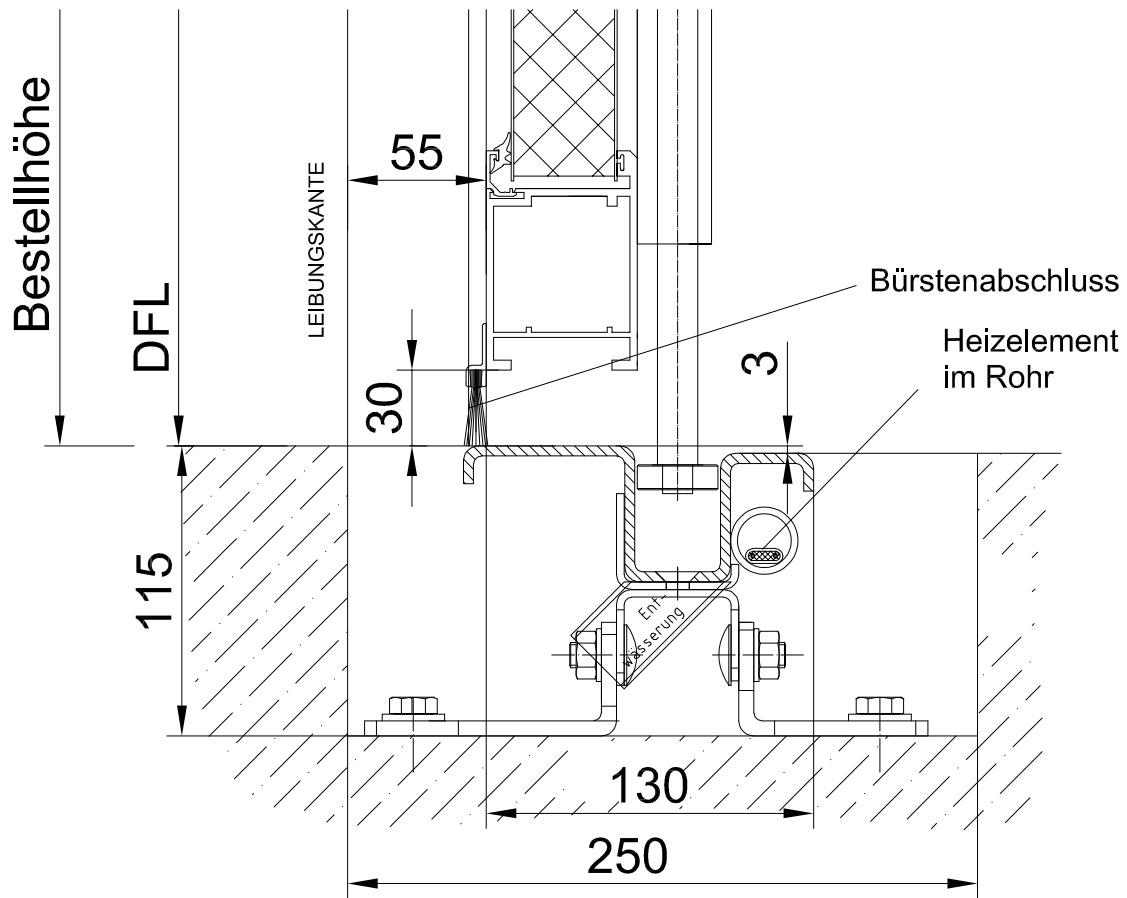

AL603S

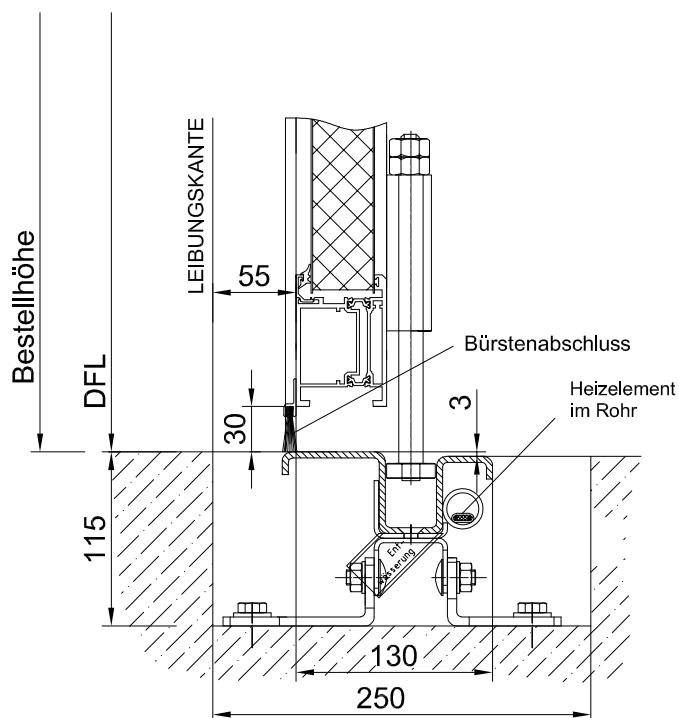

ST602S

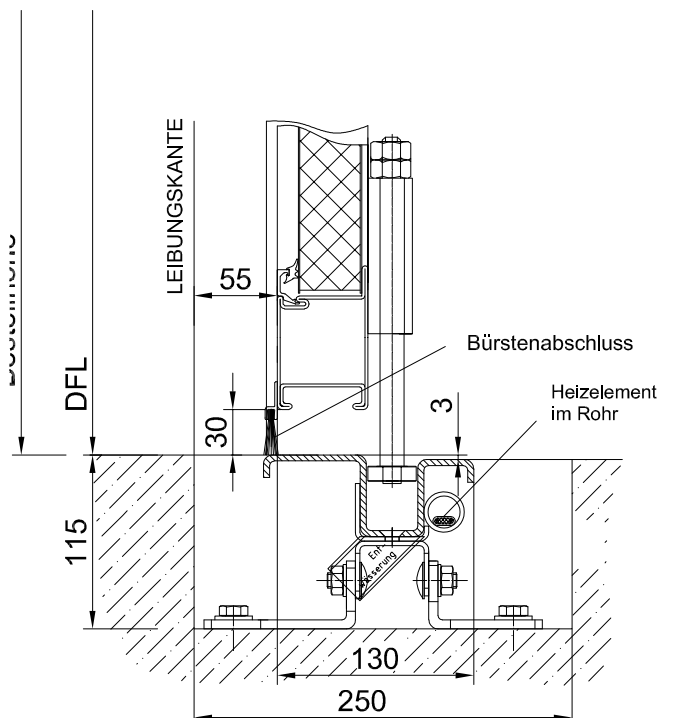

Bodenabschluss Bodenführung FOK fertig - Detail B

AL602S

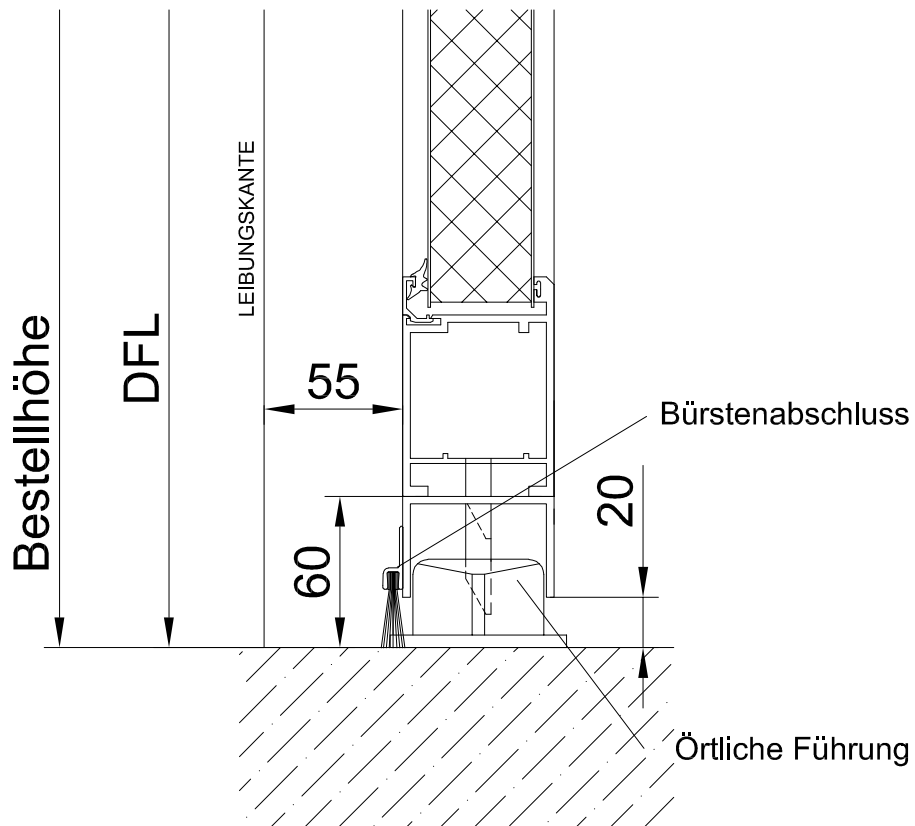

AL603S

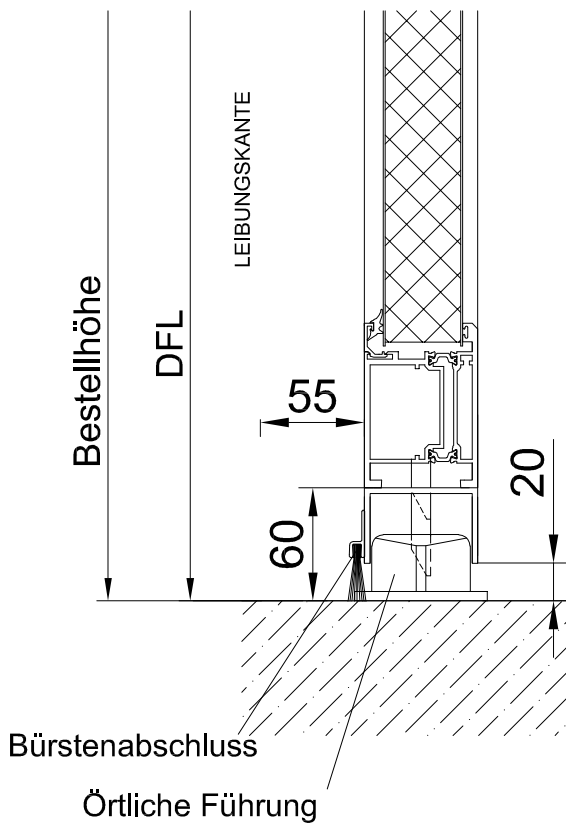

ST602S

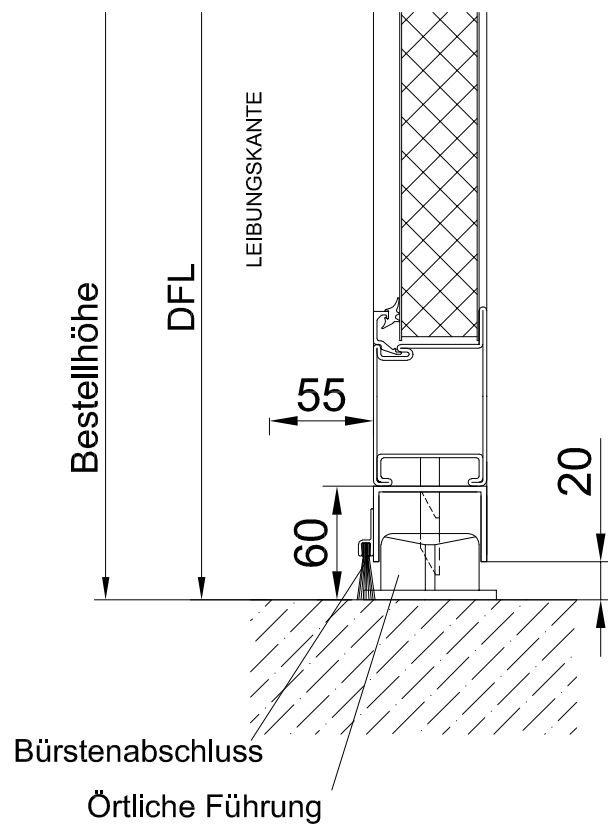

Montageposition vor/hinter der Leibung seitlich - Detail C

AL602S

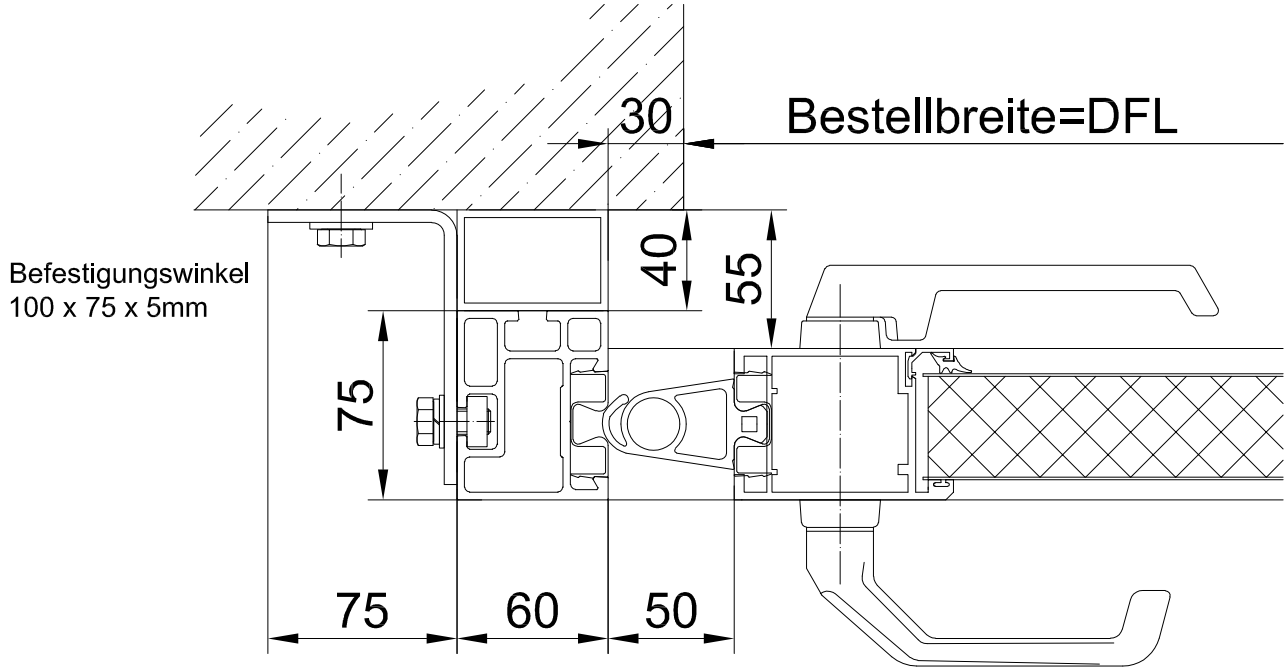

AL603S

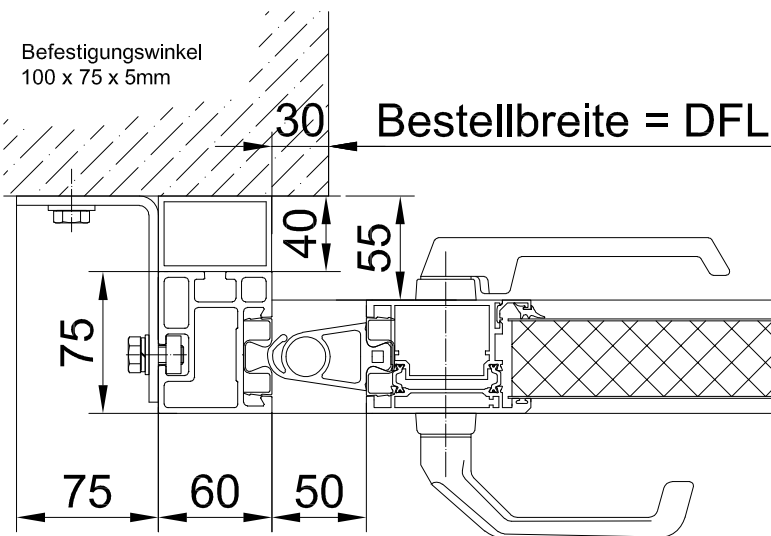

ST602S

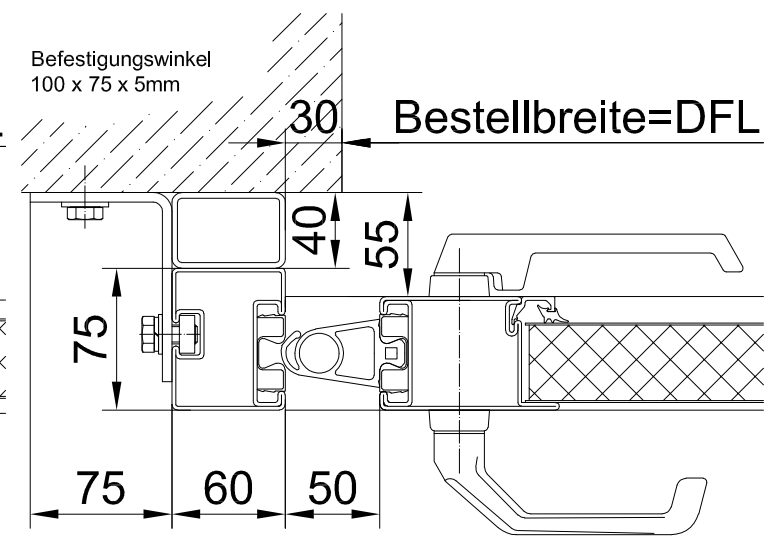

Montageposition vor/hinter der Leibung seitlich - Detail D

AL602S

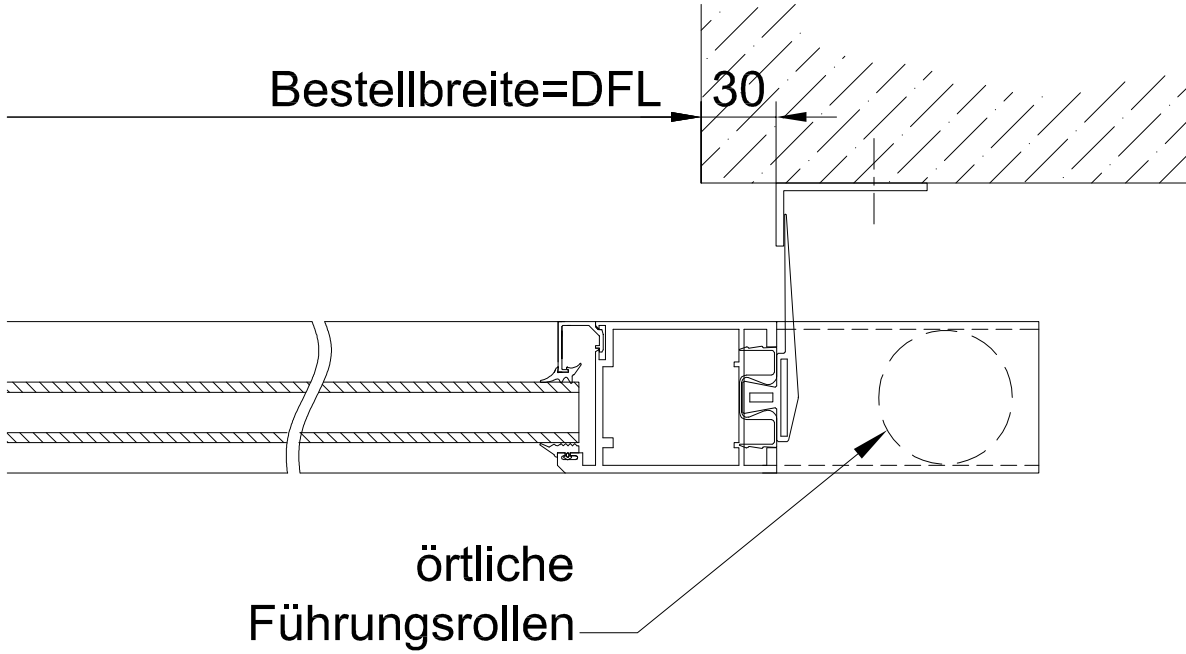

AL603S

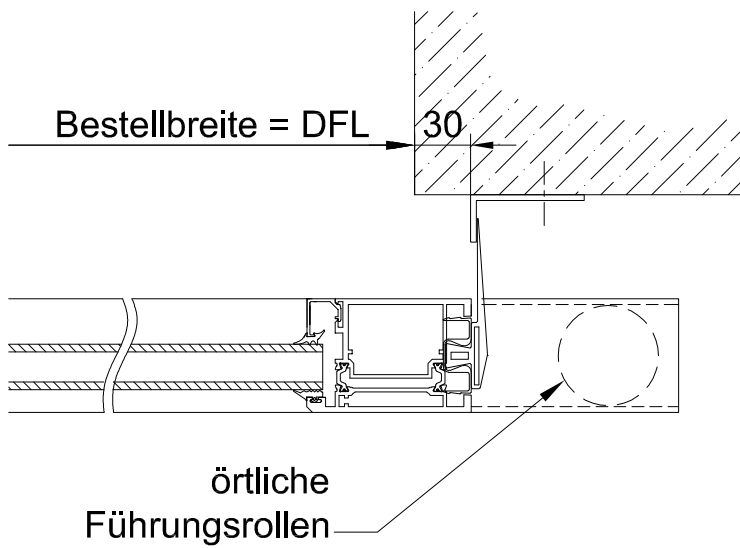

ST602S

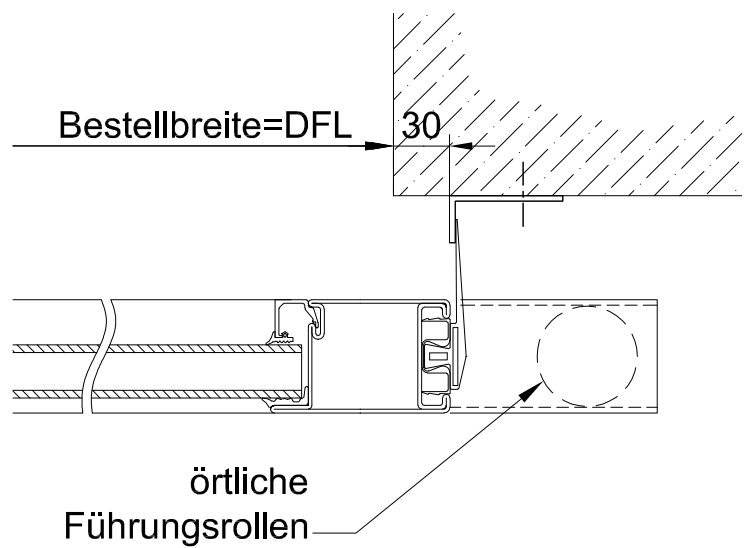

Kämpfer (Sprosse)

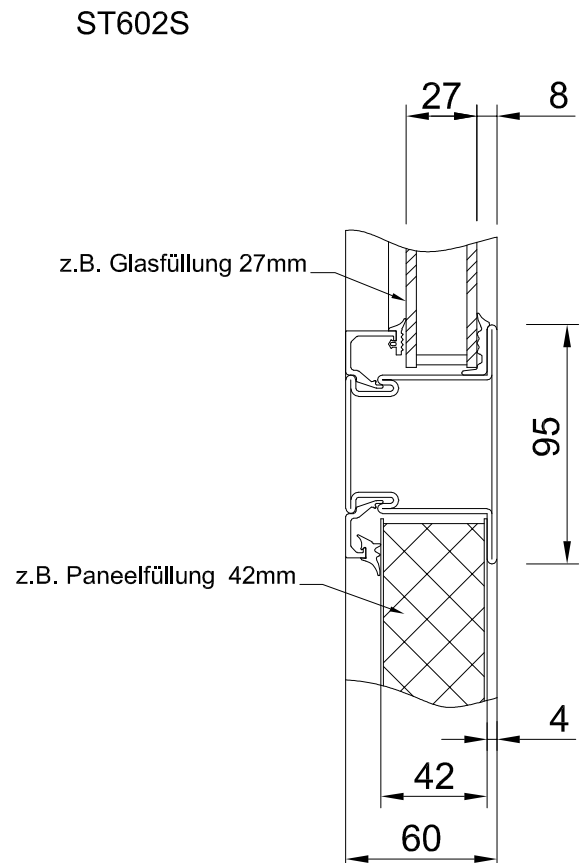
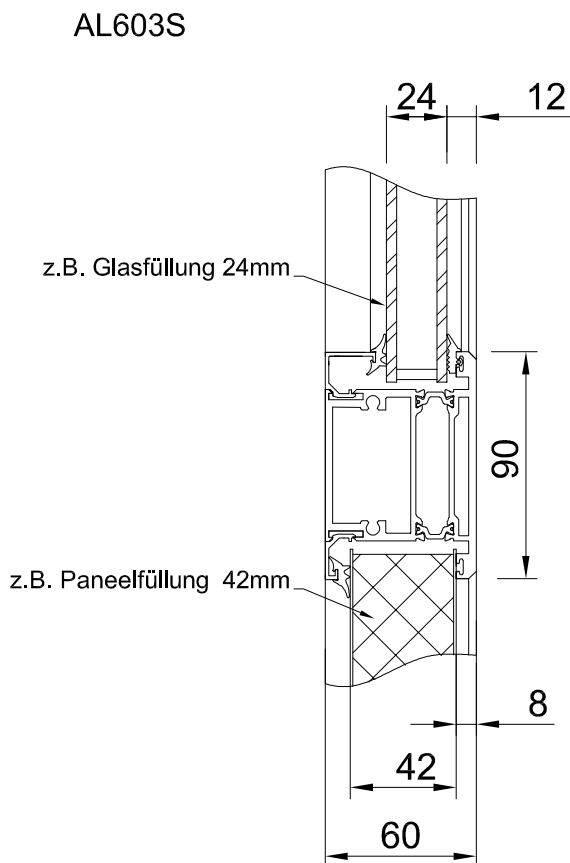
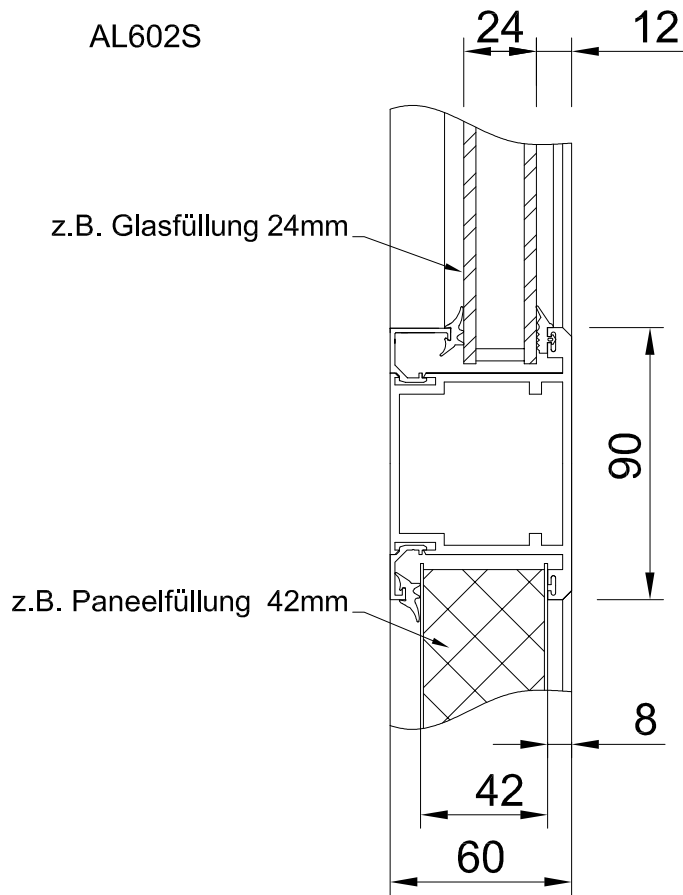

Horizontalschnitt Schlupftüre

AL602SF

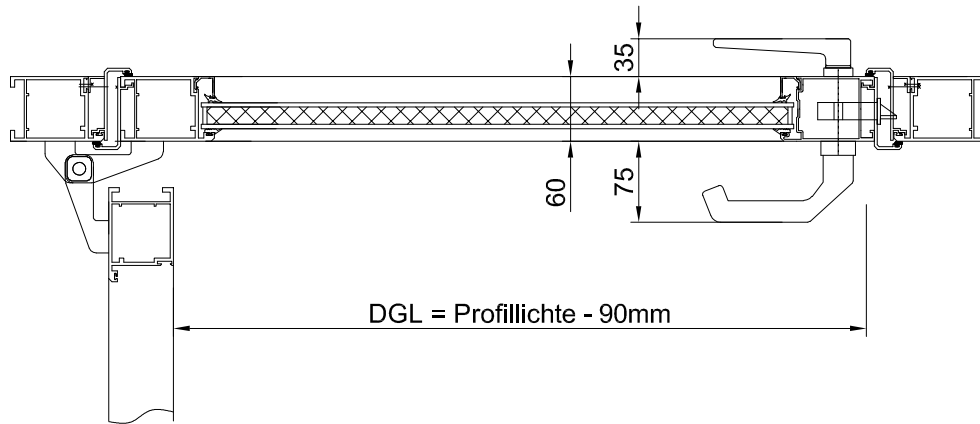

AL603SF

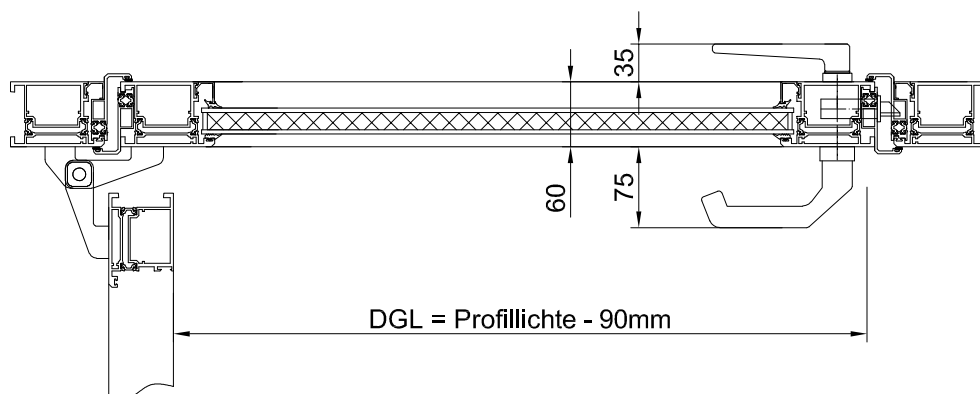

ST602SF

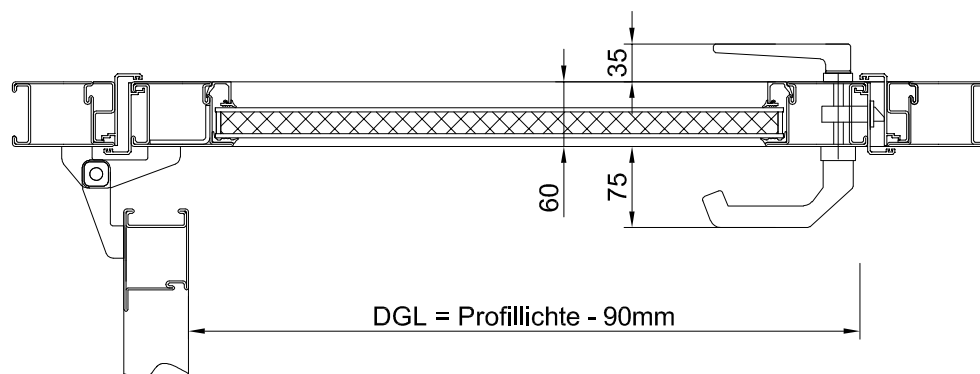

Vertikalschnitt Schlupftüre

AL602SF

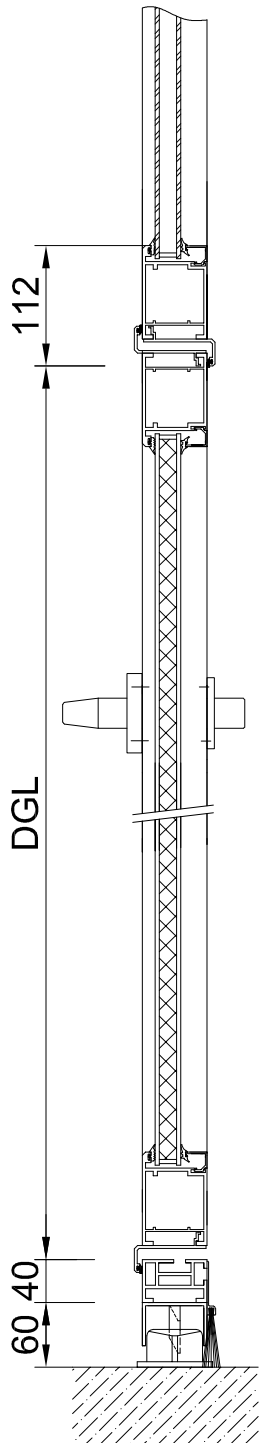

AL603SF

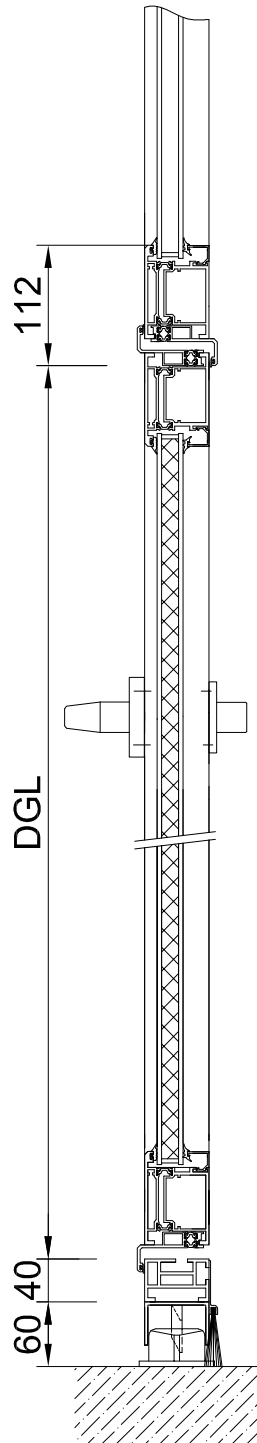

ST602SF

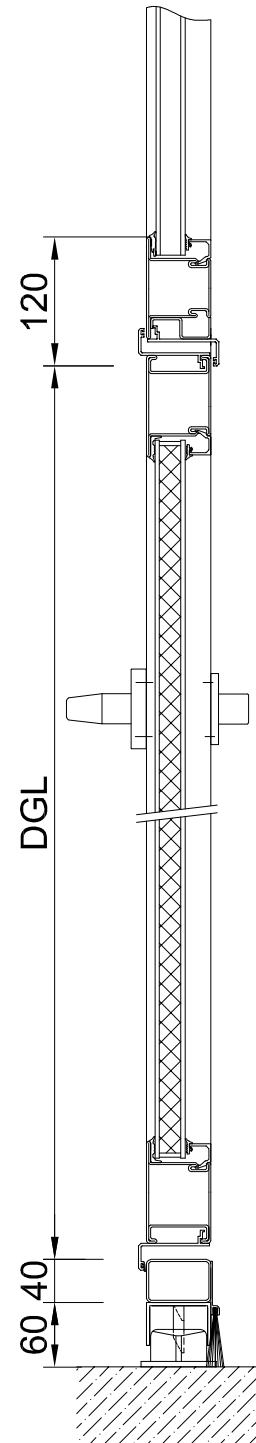

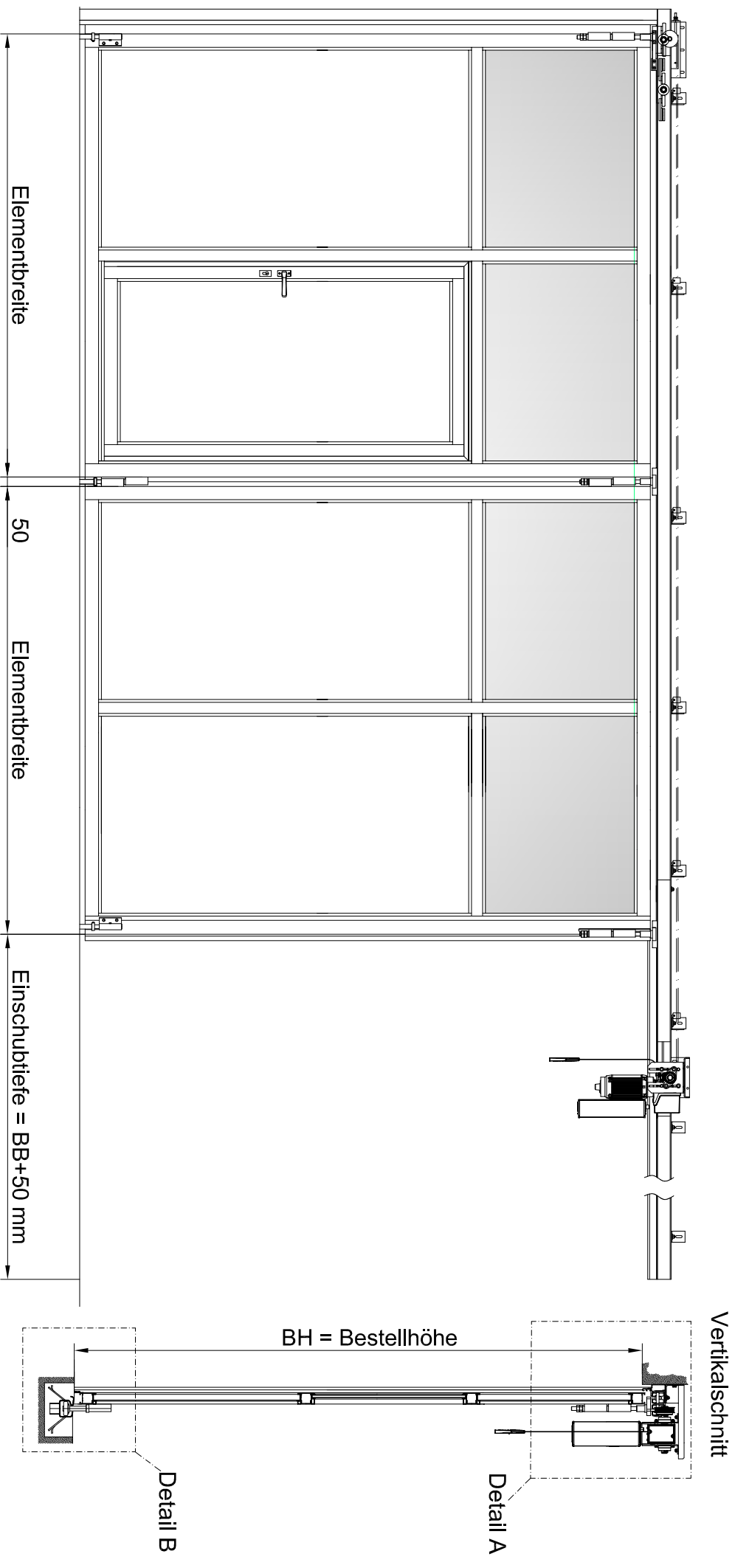

Größenbereich Schiebeter

Type	AL602S	AL603S	ST602S
Material	Aluminium	Aluminium thermisch getrennt	Stahl
max. Torgröße BB x BH	13000 x 5600 mm	13000 x 5600 mm	13000 x 5600 mm
max. Elementbreite	2900 mm	2900 mm	2900 mm

Systemzeichnung Schiebeter mit Antrieb AL602S, AL603S, ST602S

E-Antrieb - Detail A

